

Tubular Heaters

Tubular Heaters	Sheath Materials	Max. Operating Temperatures		Typical Max. Watt Densities		Page
		°F	°C	W/in ²	W/cm ²	
WATROD™ Single-Ended Double-Ended	Alloy 800/840	1600	870	45	6.9	61
	Stainless steel	1200	650	60	9.3	
	Steel	750	400	45	6.9	
	Alloy 600	1800	982	45	6.9	
High-Temperature	Alloy 600	1800	982	45	6.9	87
MULTICOIL™	Alloy 800	1400	760	45	6.9	89
	304 stainless steel	1200	650	45	6.9	
	316 stainless steel	1200	650	45	6.9	
Milled Groove	304 stainless steel	1200	650	60	9.3	91
	Alloy 800	1600	870	60	9.3	
FIREBAR® Single-Ended Double-Ended	Alloy 800	1400	760	60	9.3	93
	304 stainless steel	1200	650	60	9.3	
FINBAR™ Single-Ended	304 stainless steel	1200	650	50	7.7	112

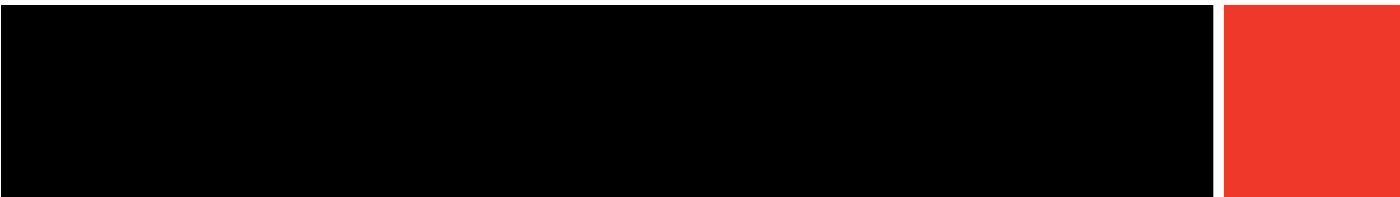

Tubular Heaters



Tubular Heaters

WATROD™ Single/Double-Ended Heaters

Available in single- or double-ended termination styles, the versatile and economical WATROD™ tubular heating element from Watlow® lends itself to virtually the entire range of immersion and air heating applications.

The single-ended WATROD tubular design has both terminals at one end. The opposite end is sealed. Flexible lead wires are 12 in. (305 mm) crimp connected to the terminal pin and have silicone-impregnated fiberglass oversleeves.

The double-ended WATROD, with its round cross-sectional geometry, is highly adaptable for bending—especially when bending is performed in the field. Watlow's double-ended MULTICOIL™ tubular elements offer various combinations of resistor coils and thermocouples inside one sheath. They have the ability to sense the heater's internal temperature accurately every time, or offer three-phase capability in one element.

Both single- and double-ended WATRODs share many construction features delivering long life—the resistance wire is centered in the heater sheath and electrically insulated with compacted, high-grade magnesium oxide for superior heating performance.

WATROD heating elements have a variety of mounting and termination options making them highly popular among industrial customers.

Single-Ended WATROD Performance Capabilities

- Watt densities up to 45 W/in² (6.9 W/cm²)
- UL® and CSA component recognition up to 240VAC
- Alloy 800/840 and stainless steel sheath temperatures up to 1200°F (650°C)

Double-Ended WATROD Performance Capabilities

- Watt densities up to 120 W/in² (18.6 W/cm²)
- UL® and CSA component recognition up to 600VAC
- Alloy 800/840 sheath temperatures up to 1600°F (870°C)
- Stainless steel sheath temperatures up to 1200°F (650°C)
- Steel sheath temperatures up to 750°F (400°C)
- Alloy 800 sheath temperatures up to 1800°F (982°C)

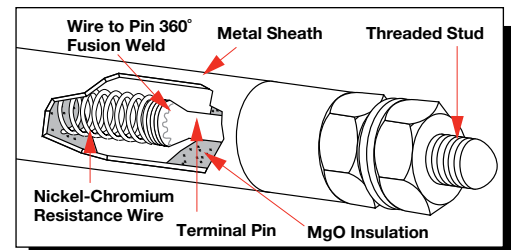
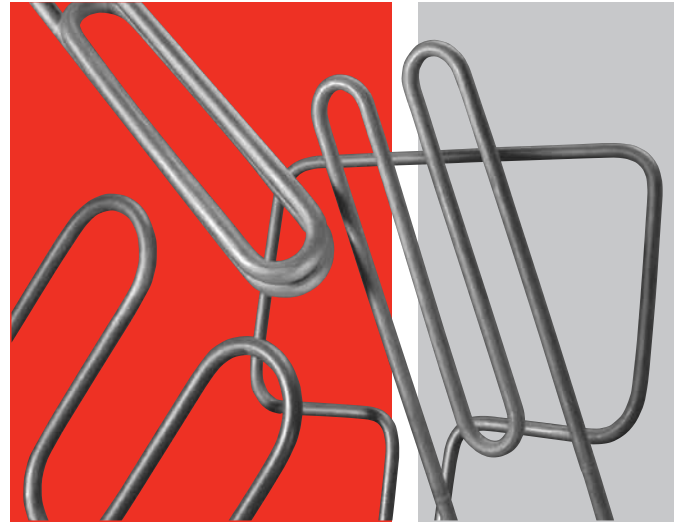

Features and Benefits

Precision wound nickel-chromium resistance wire

- Distributes heat evenly to the sheath for optimum heater performance

Silicone resin seals

- Protects against moisture contamination and is rated to 221°F (105°C)

MgO insulation filled sheath

- Maximizes dielectric strength, heat transfer and life

Standard sheath materials

- Steel, 304 and 316 stainless steel, alloy 800/840 and alloy 600

53 standard bend formations

- Allows forming the heating element to the application. Spirals, compound bends and multi-axis and multi-plane configurations

Stainless steel studs

- Fusion welded to terminal pins for mechanical strength

Popular termination, mounting and moisture seal options available

Tubular Heaters

WATROD Single/Double-Ended Heaters

Specifications

Double-Ended



Single-Ended



Applications	Direct immersion Hot runner mold (manifold) Forced air Ovens Radiant Clamp-on	Vacuums Semiconductor	Platens Forced air Deicing antennas Plastic wrap cutting Seal bars
Watt Density W/in ² (W/cm ²)	Catalog P/N: Standard:	up to 60 (9.3) up to 120 (18.6)	Catalog P/N: Standard:
Element Diameters in. (mm) and Surface Area per Linear in ² (cm ²) Diameter Tolerance ± 0.005 in. (0.13 mm)	Dia. 0.210 0.260 0.315 0.375 0.430 0.475	in² 0.660 0.817 0.990 1.178 1.351 1.492	Dia. (mm) (5.33) (6.60) (8.00) (9.53) (10.92) (12.07)
			cm² (4.26) (5.27) (6.38) (7.60) (8.72) (9.63)
Sheath Materials Max. Operating Temperature	Standard: 316 SS Steel 304 SS Alloy 600	Alloy 800/840 1600°F (870°C) 1200°F (650°C) 750°F (400°C) 1200°F (650°C) 1800°F (980°C)	Standard: 316 SS 304 SS 1200°F (650°C) 1200°F (650°C)
Sheath Length By Diameter in. (mm)	Dia. Standard: 0.210 0.260 0.315 0.375 0.430 0.475	Sheath Length (in.) 9 to 130 9 to 270 9 to 270 11 to 360 11 to 360 11 to 275	Sheath Length (mm) (5.33) (6.60) (8.00) (9.53) (10.92) (12.07)
			Sheath Length (mm) (230 to 3300) (230 to 6858) (230 to 6858) (280 to 9144) (280 to 9144) (280 to 6985)
Min. No-Heat Length in. (mm)	Sheath Length 11 to 20 21 to 50 51 to 80 81 to 110 111 to 140 141 to 170 171 to 200 201 & up	No-Heat Length 1 1 ¹ / ₄ 1 ¹ / ₂ 1 ⁵ / ₈ 1 ³ / ₄ 2 2 ¹ / ₄ 2 ¹ / ₂	Sheath Length (280 to 510) (535 to 1270) (1295 to 2030) (2055 to 2795) (2820 to 3555) (3580 to 4320) (4345 to 5080) (5105 & up)
			No-Heat Length (25) (32) (38) (42) (44) (51) (57) (64)
Max. Voltage/Amperage By Dia. in. (mm)	Dia. 0.260 (6.6) 0.315 (8.0) 0.375 (9.53) 0.430 (10.92) 0.475 (12.07)	Volts 250VAC 480VAC 480VAC 600VAC 600VAC	Amperes 15 30 30 40 40
			Single-Ended Dia. 0.375 (9.53) 0.430 (10.92) 0.475 (12.07)
			Volts 480VAC 480VAC 480VAC
			Ampere 30 30 30
			1/2 in. (13 mm) No-heat length on all blunt ends

Tubular Heaters

WATROD Single/Double-Ended Heaters

Specifications (Continued)

Double-Ended

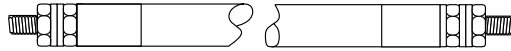

Single-Ended



Ohms Per Heated Inch By Dia. in.	Double-Ended			Single-Ended		
	Dia.	Min.	Max.	Dia.	Min.	Max.
	0.210	0.130Ω	14Ω	0.375	0.150Ω	25Ω
	0.260	0.080Ω	16Ω	0.430	0.150Ω	24Ω
	0.315	0.050Ω	25Ω	0.475	0.150Ω	22Ω
	0.375	0.030Ω	20Ω			
	0.430	0.030Ω	25Ω			
	0.475	0.035Ω	25Ω			
Terminations	Standard:	Threaded stud Screw lug (plate) Quick connect (spade) Flexible lead wires		Standard:	Flexible lead wires Rubber overmolds	
Seals	Standard:	Silicone resin	221°F (105°C)	Standard:	Silicone resin	221°F (105°C)
		Ceramic base	2800°F (1535°C)		Silicone rubber (RTV)	500°F (260°C)
		Ceramic-to-metal	482°F (250°C)		Epoxy resin	194/356°F (90/180°C)
		Silicone rubber (RTV)	392°F (200°C)			
		Silicone resin	392°F (200°C)			
		Epoxy resin	194/356°F (90/180°C)			
Mounting Options	Threaded bulkheads Mounting brackets Locator washers Mounting collars			Threaded bulkhead Locator washers Mounting collars		
Surface Finish Options	Oxide anneal Bright anneal Passivation			Oxide anneal Bright anneal Passivation		
Agency Recognition	UL® Component to 480VAC (File # E52951/E56488) CSA Component to 600VAC (File # 31388)			UL® Component to 240VAC (File # E52951) CSA Component to 240VAC (File # 31388) ①		

① Not applicable to 0.375 inch diameter single-ended WATROD.

Tubular Heaters

WATROD Single/Double-Ended Heaters

Options

Moisture Resistant Seals

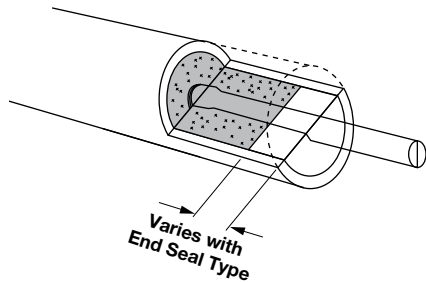

WATROD's MgO insulating material is hygroscopic. To control the rate of moisture entering the heater, an appropriate moisture seal must be used. Choosing the correct seal is important to the life and performance of the heater. All materials have varying rates of gas vapor transmission. Be sure the maximum continuous use temperature is not exceeded at the seal location. Most end seals are applied with a small cavity in the end of the heater. The seal will also help prevent arcing at the terminal ends

Zoned Heaters

Single zone heaters are only available.

External Finishes

Bright Annealing

Bright annealing is a process that produces a smooth, metallic finish. It is a special annealed finish created in a non-oxidizing atmosphere. This finish is popular in the pharmaceutical and food and beverage markets.

To order, specify **bright annealing**.

Passivation

During the manufacturing process, particles of iron or tool steel may become embedded in the stainless steel or alloy sheath. If not removed, these particles may corrode, produce rust spots and/or contaminate the process. For critical sheath applications, passivation will remove free iron from the sheath.

To order, specify **passivation**.

Ceramic-to-Metal End-Seal

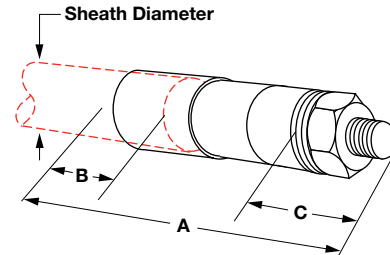

Ceramic-to-metal end-seals with threaded stud terminations provide an air-tight seal for continuous terminal temperatures up to 500°F (260°C). Watlow does not recommend this seal if terminations are exposed to temperatures exceeding 500°F (260°C).

Sheath Diameter in. (mm)	A in. (mm)	B in. (mm)	C in. (mm)	Thread Size
0.260 (6.6)	1 11/16 (42.9)	1/2 (13)	13/32 (10.32)	#8-32
0.315 (8.0)	1 7/8 (47.6)	1/2 (13)	13/32 (10.32)	#10-32
0.430 (10.9)	2 1/8 (54.0)	1/2 (13)	13/32 (10.32)	#1/4-28

Tubular Heaters

WATROD Single/Double-Ended Heaters

Options (Continued)

End-Seal Options

End-Seal	Part Number	Color	UL® Recognition	Max. Cont. Use Temperature	Typical or General Usage/Application
Standard Epoxy	EC	Cream	Yes	194°F (90°C)	Long term stable insulation resistance
Intermediate Epoxy	EB	Gray	Yes	356°F (180°C)	Long term stable insulation resistance
High-Temp. Epoxy	HTE	Amber	No	450°F (232°C)	Long term stable insulation resistance
Silicone Resin	SR	Clear	Yes	221°F (105°C)	General usage on tubular products - porous
Silicone Fluid	SF	Clear	No	392°F (200°C)	Moisture resistance of the MgO, or high temperature ceramic seal (storage only) - porous
Lavacone	LC	Dark Brown	Yes	221°F (105°C)	Porous seal for the FIREBAR
Silicone Rubber RTV	RTV	Red-Orange	Yes	392°F (200°C)	General usage on FIREBAR applications - porous
High-Temperature Ceramic	HTC	White	Yes	2800°F (1538°C)	Very high-temperature applications - for extremely low vapor transmission rate

Tubular Heaters

WATROD Single/Double-Ended Heaters

Terminations

Double-ended WATROD elements are available with a variety of terminations. Single-ended WATROD elements are available with only flexible lead wires.

The following table and illustrations detail the terminations available with double- or single-ended WATRODs—for each available sheath diameter.

Flexible lead wires are 12 in. (305 mm), Sil-A-Blend™ 390°F (200°C) unless otherwise specified. Insulation options include TGGT 480°F (250°C) plus other temperature ratings. Contact your Watlow representative.

Overmolds are available for flexible lead wires only. Available in silicone rubber 390°F (200°C) and neoprene 212°F (90°C). Contact your Watlow representative.

WATROD Element	Sheath Diameter in. (mm)		Threaded Stud ①	Screw Lug (Plate)				Quick Connect (Spade)			Flexible Lead Wires
			A	B	C	D	E	F	G	H	
Double-Ended	0.260	(6.6)	#6-32	Yes	Yes	Yes	Yes	Yes	Yes	Yes	Yes
	0.315	(8.0)	#10-32	Yes	Yes	Yes	Yes	Yes	Yes	Yes	Yes
	0.335	(8.5)	#10-32	Yes	Yes	Yes	Yes	Yes	Yes	Yes	Yes
	0.375	(9.5)	#10-32	Yes	Yes	Yes	Yes	Yes	Yes	Yes	Yes
	0.430	(10.9)	#10-32	Yes	Yes	Yes	Yes	Yes	Yes	Yes	Yes
	0.475	(12.1)	#10-32	Yes	Yes	Yes	Yes	Yes	Yes	Yes	Yes
Single-Ended	0.490	(12.5)	#10-32	Yes	Yes	Yes	Yes	Yes	Yes	Yes	Yes
	0.375	(9.53)	No	No	No	No	No	No	No	No	Yes
	0.430	(10.9)	No	No	No	No	No	No	No	No	Yes
	0.475	(12.1)	No	No	No	No	No	No	No	No	Yes
	0.490	(12.5)	No	No	No	No	No	No	No	No	Yes

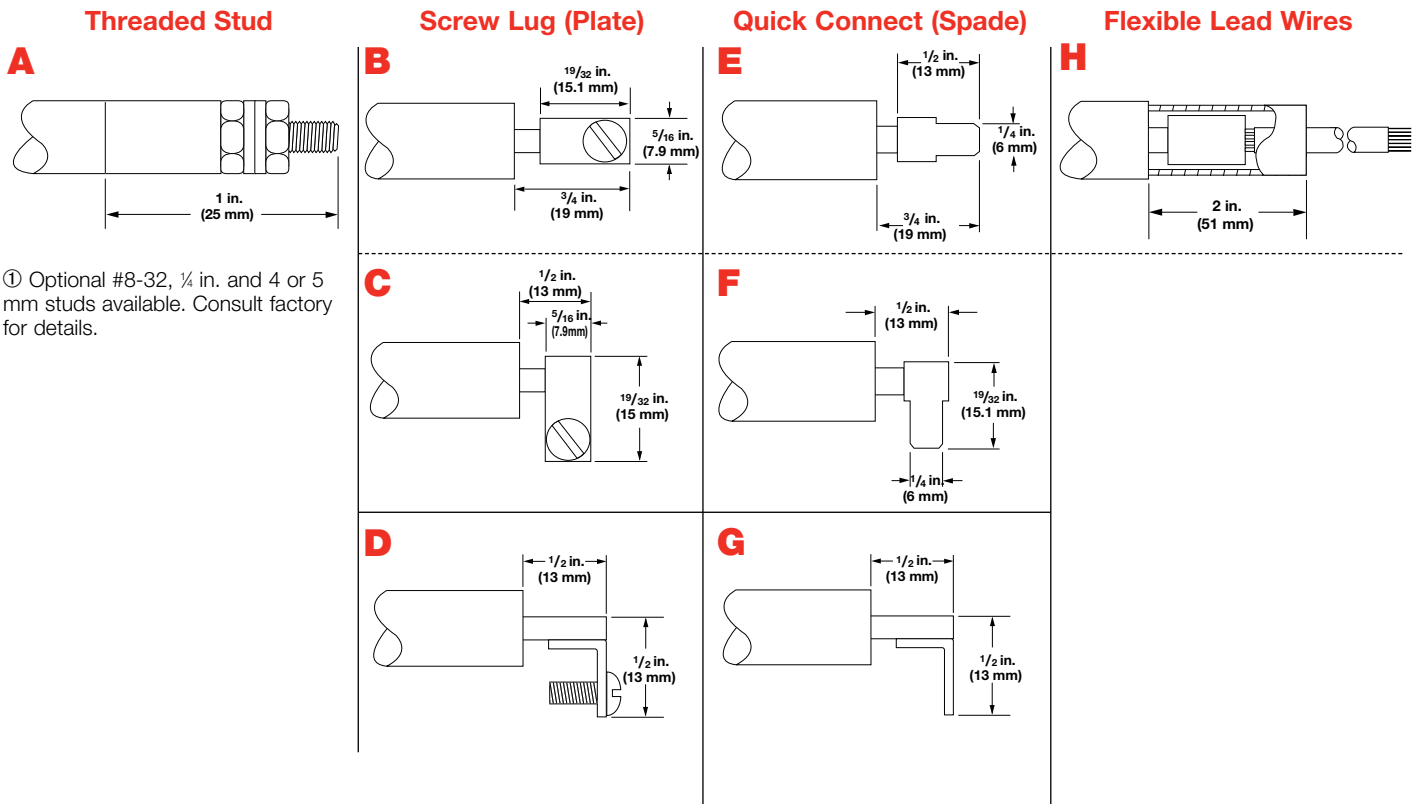

Tubular Heaters

WATROD Single/Double-Ended Heaters

Bend Formations

Double-Ended WATROD Bend Formations

Double-ended WATROD heating elements can be formed into spirals, compounds, multi-axis and multi-planes from 36 common bend configurations. Custom bending with tighter tolerances can be made to meet specific application needs.

Formation is limited by the minimum bend radius (R) and the straight length (F) required beyond the bend. In order to locate the end of a heated length within a bend, the radius must be 3 in. (76 mm) or larger. Additionally, overall length tolerance (T) must be included in one or more of the straight lengths.

Minimum radius for various sheath diameters and lengths are shown in the *Bend Formations* chart below. Illustrated on pages 67 to 76 are the 51 common bend configurations available on both stock and made-to-order WATROD heating elements.

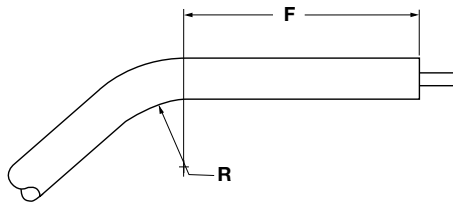

WATROD Length Tolerance (T)			
Sheath Length		Length Tolerance	
in.	(mm)	in.	(mm)
11-50	(280-1270)	±1/8	(±3)
51-110	(1295-2795)	±3/16	(±5)
111-170	(2820-4320)	±1/4	(±6)
171-200	(4345-5080)	±3/8	(±10)
201 & up	(5105 & up)	±1/2	(±13)

Single-Ended WATROD Bend Formations

Watlow does not recommend field bending single-ended WATROD elements. Formation is limited by the minimum radius of a bend (R) and the straight length (F) beyond the bend. The radius must be 3 in. (75 mm) or more for the heated length's end to be inside a bend.

Additionally, the overall length tolerance (T) must be provided for in one or more of the specified lengths.

The four common bend configurations available for standard and made-to-order single-ended WATROD elements are Figures 1, 6, 22 and 28.

To order a common bend formation, specify the **bend figure number**, dimensions and critical tolerances.

WATROD Minimum Radius							
Sheath Diameter in.	(mm)	Field Bend R ^①		Factory R ^①		F ^② Dimension in.	(mm)
		in.	(mm)	in.	(mm)		
0.260	(6.6)	3/4	(19.0)	3/8	(9.5)	1/2	(13.0)
0.315	(8.0)	3/4	(19.0)	1/2	(13.0)	1/2	(13.0)
0.375	(9.52)	1	(25.0)	1/2	(13.0)	1/2	(13.0)
0.430	(10.92)	1	(25.0)	1/2	(13.0)	3/4	(19.0)
0.475	(12.07)	1	(25.0)	5/8	(15.9)	1	(25.0)
0.490	(12.45)	1	(25.0)	5/8	(15.9)	1	(25.0)

① R is the inside radius of a bend.

② F is the distance from the sheath's end to the start of the first bend.

Figure 1

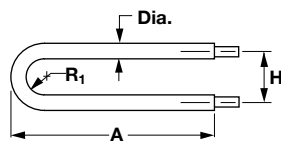

$$SL = 2A + 1.14R_1 - 0.43 \text{ Dia.}$$

(For pricing, use 1 bend)

Figure 2

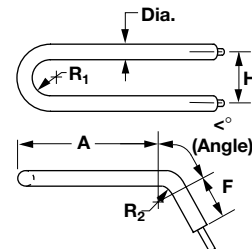

$$SL = 2A + 2F + 1.14R_1 + 0.0175 (<^\circ)$$

$$(2R_2 + \text{Dia.}) - 0.43 \text{ Dia.}$$

(For pricing, use 3 bends)

Tubular Heaters

WATROD Single/Double-Ended Heaters

Bend Formations (Continued)

Figure 3

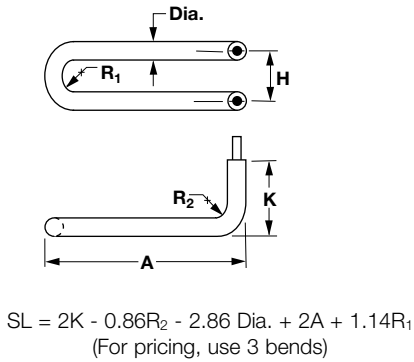

Figure 4

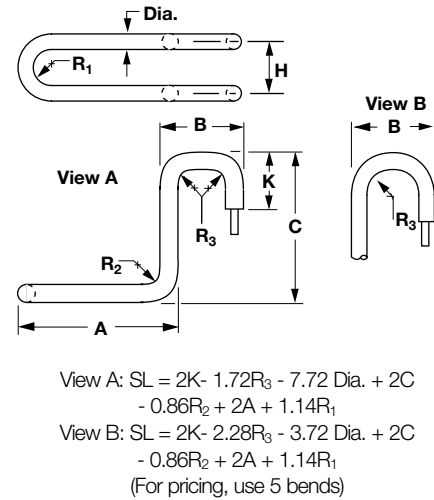

Figure 5

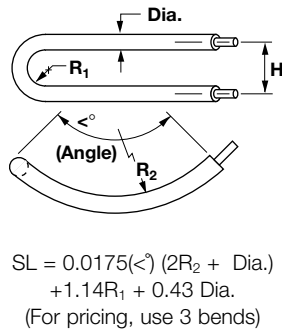

Figure 6

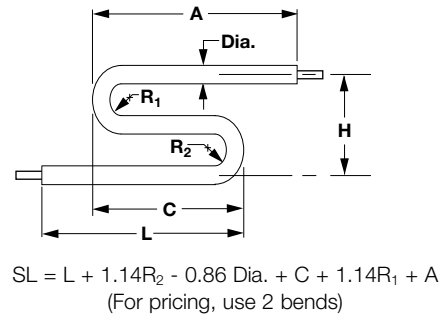

Figure 7

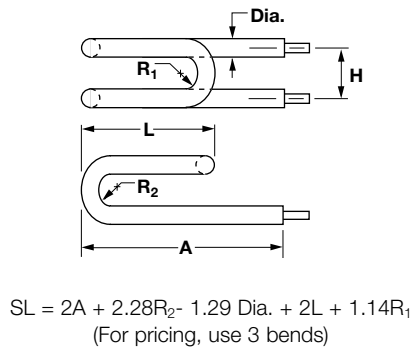

Figure 8

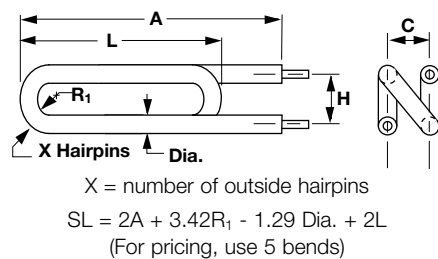
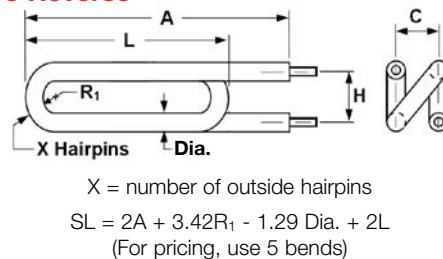

Figure 8 Reverse



Tubular Heaters

WATROD Single/Double-Ended Heaters

Bend Formations (Continued)

Figure 9

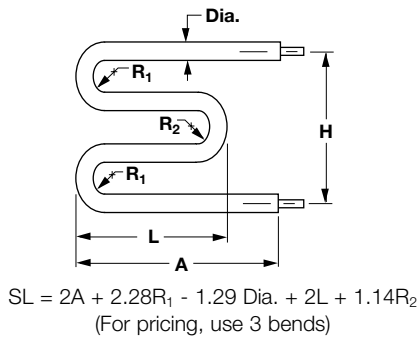

Figure 10

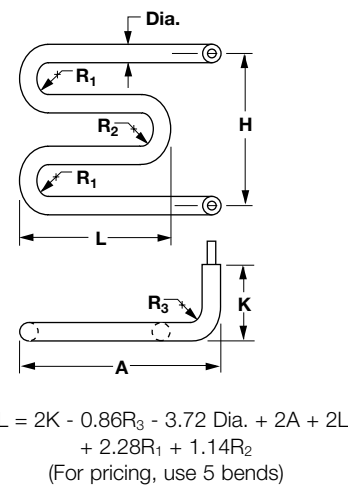

Figure 11

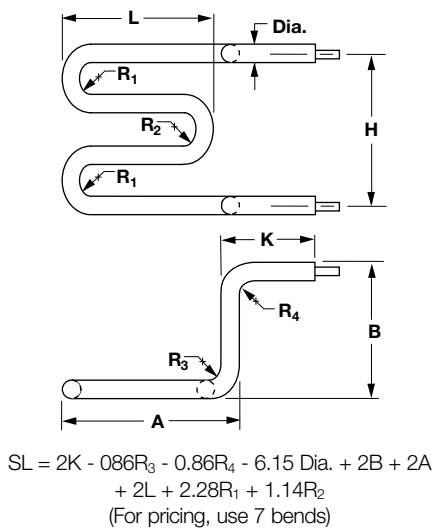

Figure 12

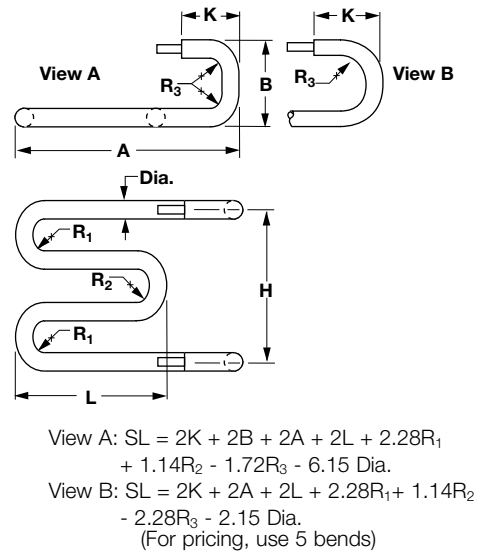

Figure 13

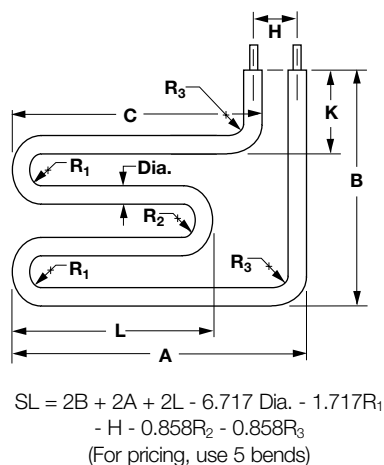
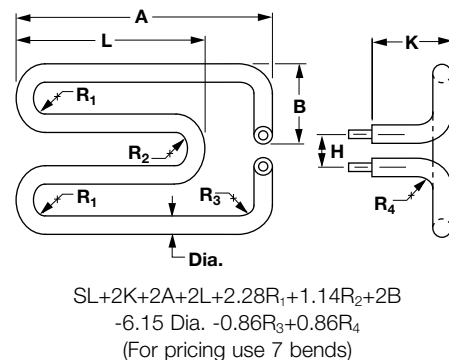

Figure 14



Tubular Heaters

WATROD Single/Double-Ended Heaters

Bend Formations (Continued)

Figure 15

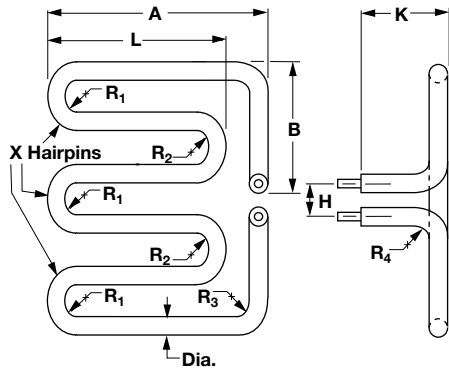

X = number of outside hairpins
 $SL = 2K + 2A + 2K(X - 1) + 2B - 0.86R_3 - 0.86R_4 + 1.14R_1(X) + 1.14R_2(X - 1) - 4.86 \text{ Dia.} - (2X - 1) 0.43 \text{ Dia.}$
 (For pricing, use 9 bends if X = 3 hairpins)

Figure 16

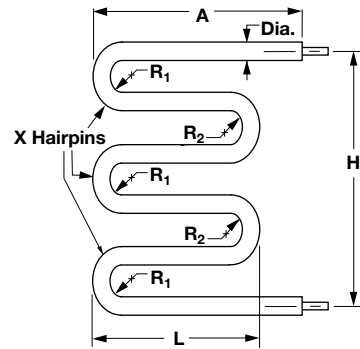

X = number of outside hairpins
 $SL = 2A + 0.43 \text{ Dia.} (1 - 2X) + 2L(X - 1) + 1.14R_1 + 1.14R_2(X - 1)$
 (For pricing, use 5 bends if X = 3 hairpins)

Figure 17

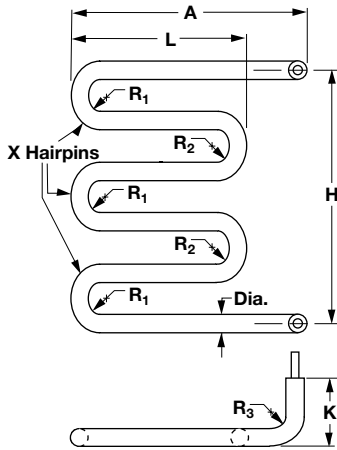

X = number of outside hairpins
 $SL = 1.14R_2X - 0.88 \text{ Dia.} X - 1.14R_2 - 2 \text{ Dia.} + 1.14R_1 X - 0.86R_3 + 2L X - 2L + 2A + 2K$
 (For pricing, use 7 bends if X = 3 hairpins)

Figure 18

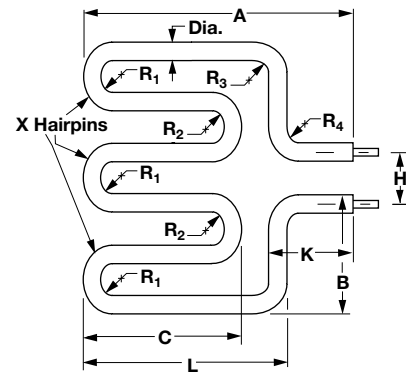

X = number of outside hairpins
 $SL = 2L + 2K + 2B + 2C(X - 1) - 0.86R_3 - 0.86R_4 - 4.86 \text{ Dia.} + 1.14R_1(X) + 1.14R_2(X - 1) - (2X - 1) 0.43 \text{ Dia.}$
 (For pricing, use 9 bends if X = 3 hairpins)

Tubular Heaters

WATROD Single/Double-Ended Heaters

Bend Formations (Continued)

Figure 19

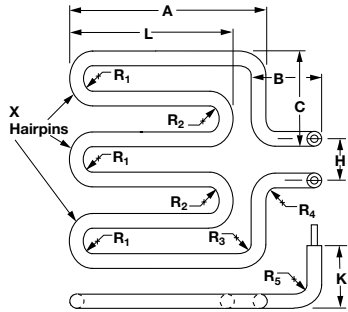

X = number of outside hairpins
 $SL = 2K + 2A + 2B + 2C + 2L(X - 1) + 1.14R_1(X) + 1.14R_2(X - 1) - 0.86R_3 - 0.86R_4 - 0.86R_5 - 7.29 \text{ Dia.} - (2X - 1) 0.43 \text{ Dia.}$
 (For pricing, use 11 bends if X = 3 hairpins)

Figure 20

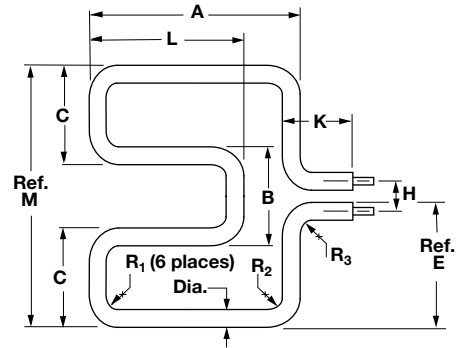

$SL = 2K + 2C + B + 2A + 2L - 2.58R_1 - 0.86R_2 - 0.86R_3 - 12.15 \text{ Dia.}$
 (For pricing, use 10 bends)

Figure 21

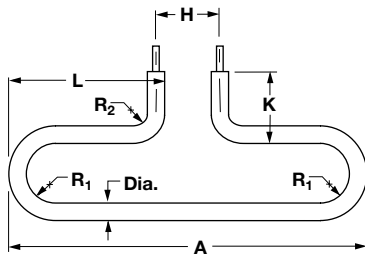

$SL = 2A + 2K - H - 2.28R_1 - 0.86R_2 - 3.29 \text{ Dia.}$
 (For pricing, use 4 bends)

Figure 22

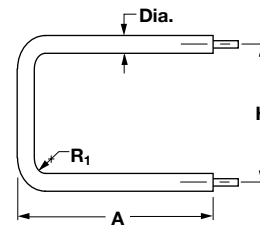

$SL = 2A - 0.86R_1 - 1.43 \text{ Dia.} + H$
 (For pricing, use 2 bends)

Figure 23

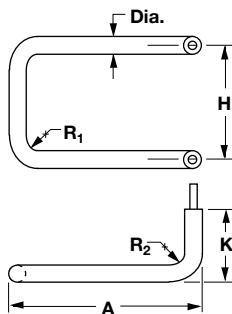

$SL = 2K - 0.86R_2 - 3.86 \text{ Dia.} + 2A - 0.86R_1 + H$
 (For pricing, use 4 bends)

Figure 24

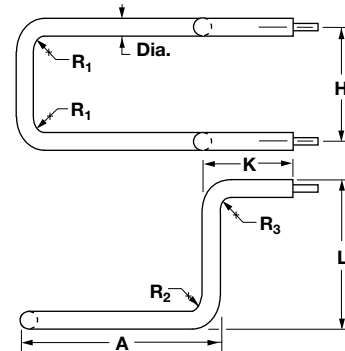

$SL = 2K + 2L + H - 0.86R_1 - 0.86R_2 - 0.86R_3 - 7.29 \text{ Dia.}$
 (For pricing, use 6 bends)

Tubular Heaters

WATROD Single/Double-Ended Heaters

Bend Formations (Continued)

Figure 25

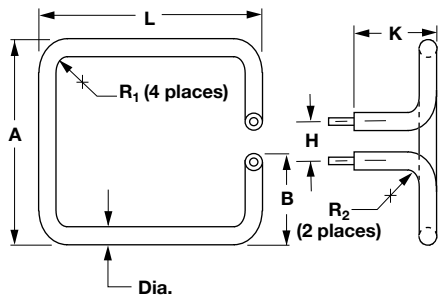

$$SL = 2K + 2A + 2L - H - 1.72R_1 - 0.86R_2 - 6.92 \text{ Dia.}$$

(For pricing, use 6 bends)

Figure 26

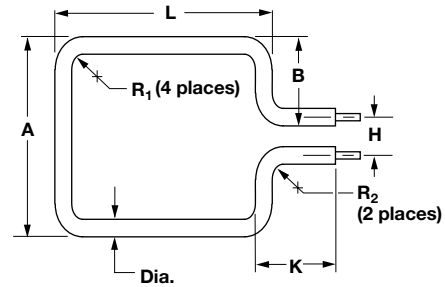

$$SL = 2K + 2A + 2L - H - 1.72R_1 - 0.86R_2 - 6.29 \text{ Dia.}$$

(For pricing, use 6 bends)

Figure 27

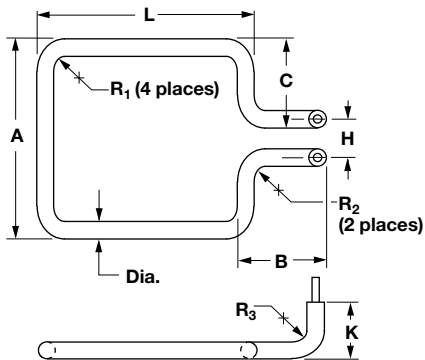

$$SL = 2K + 2A + 2L + 2B - H - 1.72R_1 - 1.72R_2 - 8.72 \text{ Dia.}$$

(For pricing, use 8 bends)

Figure 28

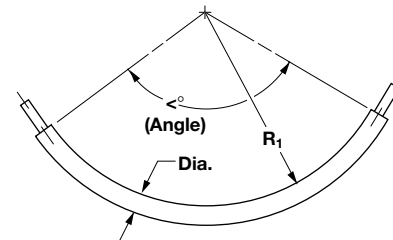

$$SL = 0.0175 \angle^\circ (R_1 + 0.5 \text{ Dia.})$$

(For pricing, use 1 bend)

Figure 29

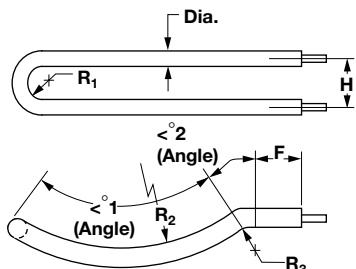

$$SL = 0.0175 \angle^1 (2R_2 + \text{Dia.}) + 2F + 1.14R_1 + 0.0175 \angle^2 (2R_3 + \text{Dia.}) - 0.43 \text{ Dia.}$$

(For pricing, use 5 bends)

Figure 30

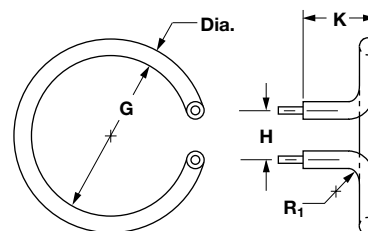

$$SL = (G + \text{Dia.}) 3.14 + 1.14R_1 + 2K + 3.28 \text{ Dia.} - H$$

(For pricing, use 4 bends)

Tubular Heaters

WATROD Single/Double-Ended Heaters

Bend Formations (Continued)

Figure 31

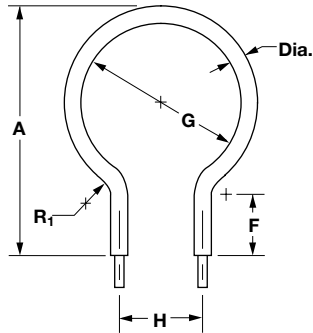

$$SL = (G + \text{Dia.}) 3.14 + 1.14R_1 + 2F + 3.71 \text{ Dia.} - H$$

(For pricing, use 4 bends)

Figure 32

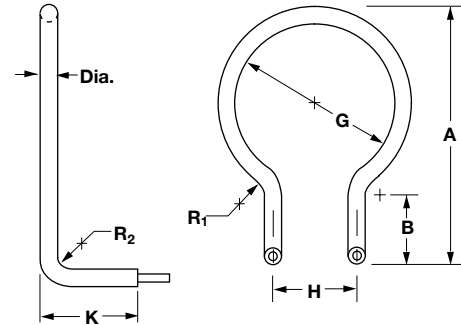

$$SL = (G + \text{Dia.}) 3.14 + 1.14R_1 + 2B + 1.14R_2 + 2K + 3.28 \text{ Dia.} - H$$

(For pricing, use 6 bends)

Figure 37

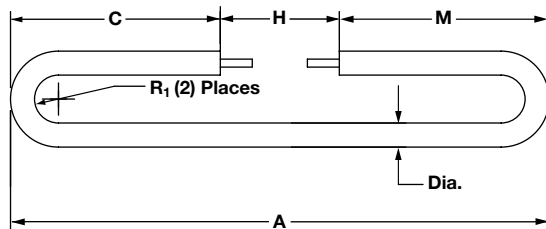

$$SL = (2A - H) + 2\pi R_1 - 2R_1$$

(For pricing, use 2 bends)

Figure 38

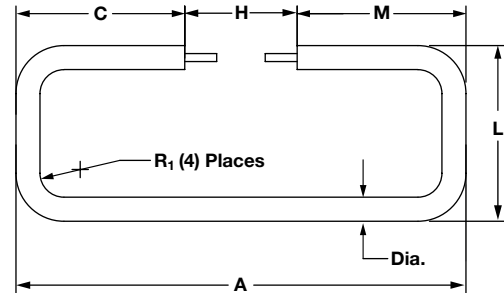

$$SL = (2A - H) + 2L + 2\pi R_1 - 4R_1$$

(For pricing, use 4 bends)

Figure 39

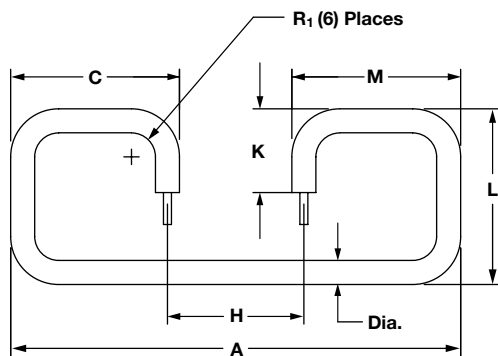

$$SL = (2A - H) + 2L + 2K + 3\pi R_1 - 6R_1$$

(For pricing, use 6 bends)

Figure 40

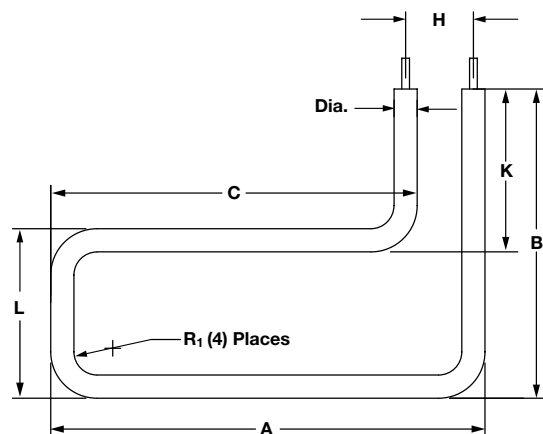

$$SL = (2A - H) + 2B + 2\pi R_1 - 4R_1$$

(For pricing, use 4 bends)

Tubular Heaters

WATROD Single/Double-Ended Heaters

Bend Formations (Continued)

Figure 41

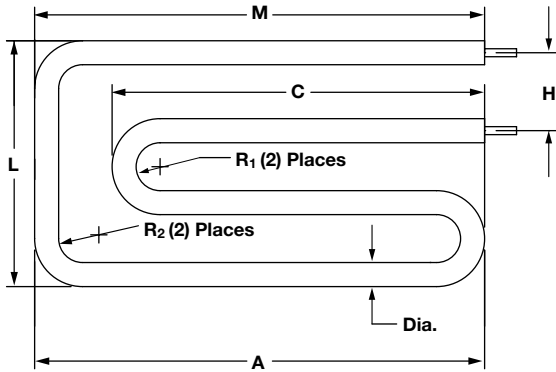

$$SL = 2A + 2C + L - H + 2\pi R_1 + \pi R_2 - 2R_1 - 2R_2$$

(For pricing, use 4 bends)

Figure 42

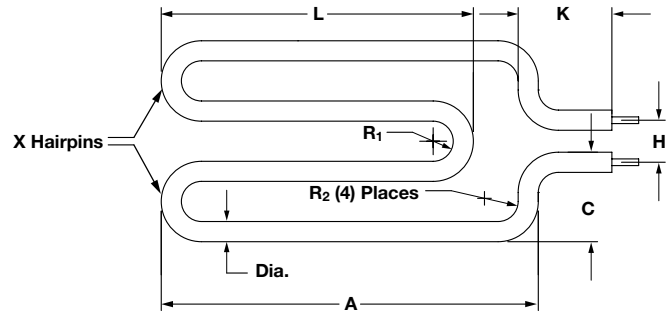

$$SL = 2A + (\#)L + 2K + 2C + 2\pi R_2 + (\# \text{ of } R_1) \pi R_1 - (\# \text{ of } R_1) R_1$$

(For pricing, use 7 bends if X = 2)

Figure 43

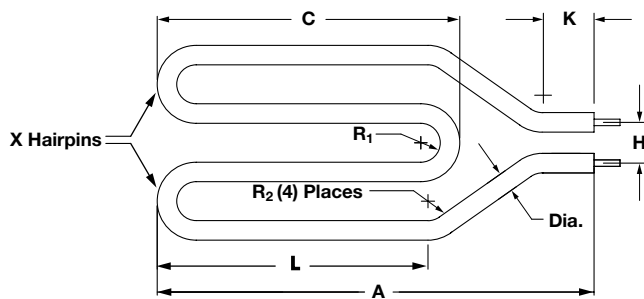

$$SL = 2A + (\#)C + (\# \text{ of } R_1) \pi + 2\pi R_2 - (\# \text{ of } R_1) R_1 - 4R_2$$

(For pricing, use 7 bends if X = 2)

Figure 44

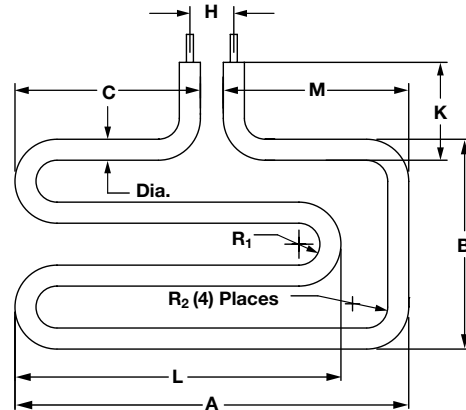

$$SL = 2A + 2L + B + 2K + 2\pi R_2 + 3\pi R_1 - 4R_2 - 3R_1$$

(For pricing, use 7 bends)

Figure 45

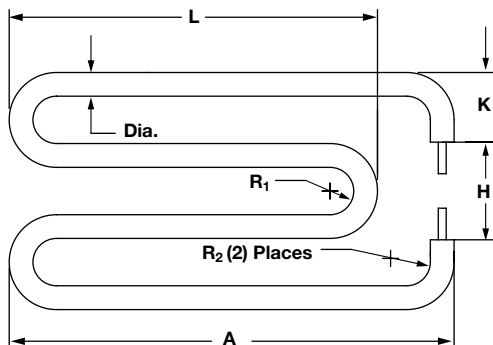

$$SL = 2A + 2L + 2K + 3\pi R_1 + \pi R_2 - 3R_1 - 2R_2$$

(For pricing, use 5 bends)

Figure 46

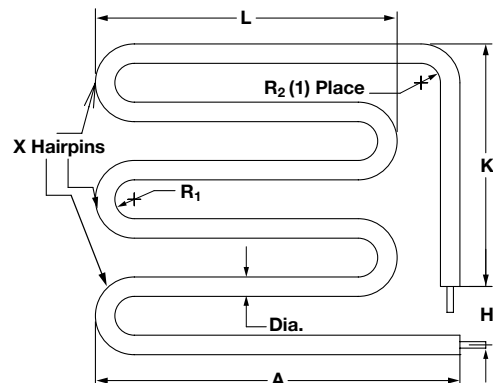

$$SL = 2A + (\#)L + K + (\# \text{ of } R_1) \pi + \frac{\pi R_2}{2} - (\# \text{ of } R_1) R_1 - R_2$$

(For pricing, use 6 bends if X = 3)

Tubular Heaters

WATROD Single/Double-Ended Heaters

Bend Formations (Continued)

Figure 47

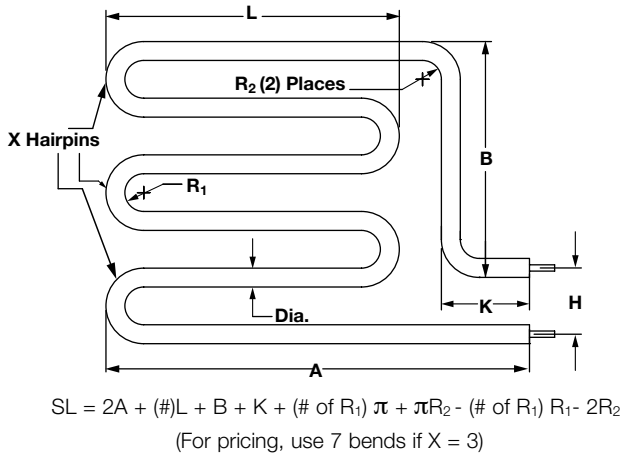

Figure 48

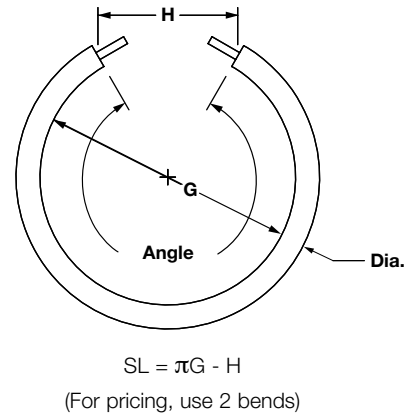

Figure 49

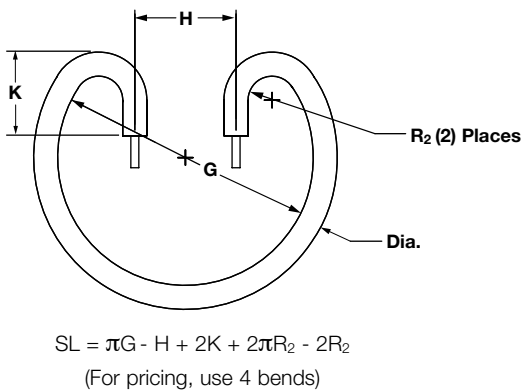

Figure 50

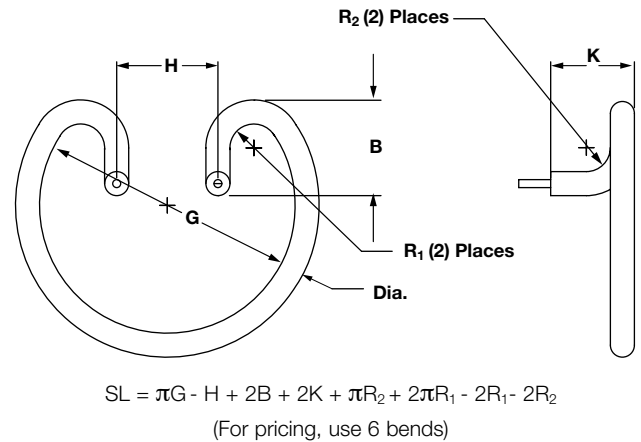

Figure 51

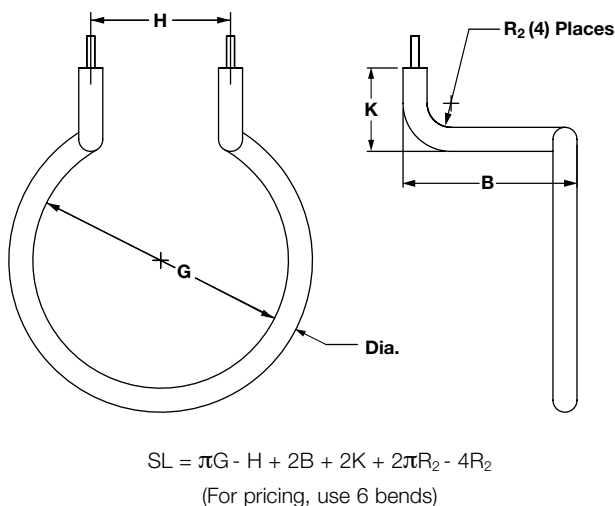
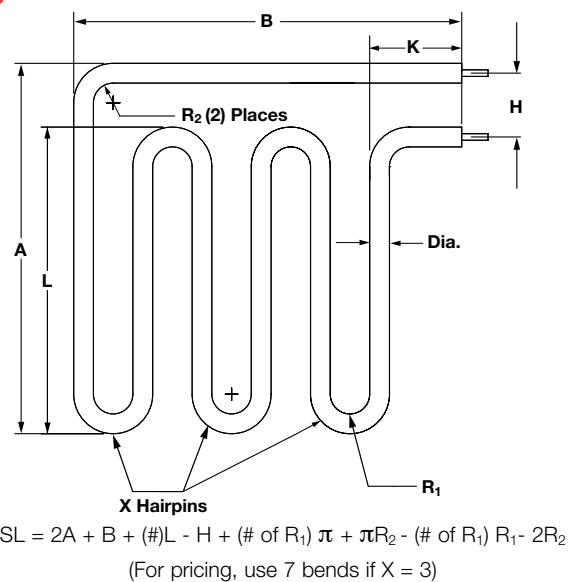

Figure 52



Tubular Heaters

WATROD Single/Double-Ended Heaters

Bend Formations (Continued)

Figure 53

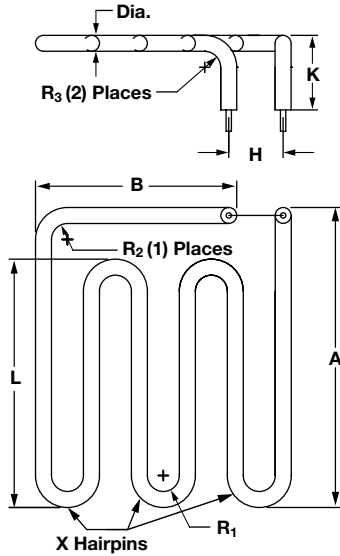

$$SL = 2A + (\#)L + B + 2K + (\# \text{ of } R_1)\pi + 2\left(\frac{\pi R_3}{2}\right) - (\# \text{ of } R_1)R_1 - 2R_3 - R_2$$

(For pricing, use 8 bends if X = 3)

Figure 54

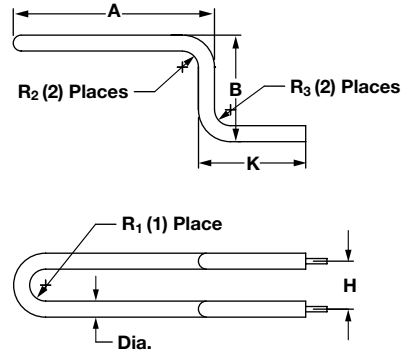

$$SL = 2A + 2B + 2K + \pi R_1 + 2\pi R_2 - R_1 - 4R_2$$

(For pricing, use 5 bends)

Figure 55

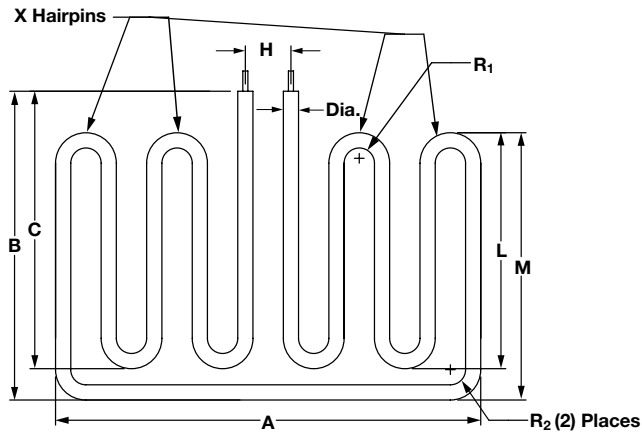

$$SL = A + 2C + 2M + (\#)L + (\# \text{ of } R_1)\pi + \pi R_2 - (\# \text{ of } R_1)R_1 - 2R_2$$

(For pricing, use 10 bends if X = 4)

Figure 56

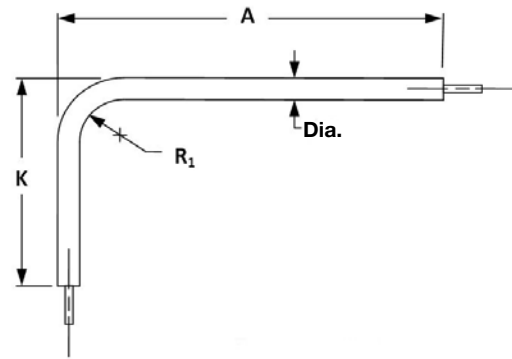

$$SL = A + K - 0.86R_1$$

(For pricing, use 1 bend)

Tubular Heaters

WATROD Single/Double-Ended Heaters

Mounting Methods

Brackets

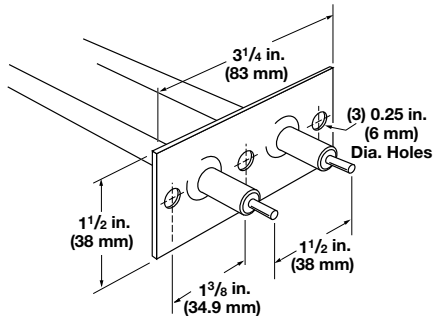

A 0.065 in. (1.7 mm) thick stainless steel bracket provides element mounting in non-pressurized applications. Attached to the heater sheath, these brackets are not suited for liquid-tight mountings. The bracket is located 1/2 in. (13 mm) from the sheath's end, unless otherwise specified.

To order, specify **mounting bracket**.

Single Leg Bracket

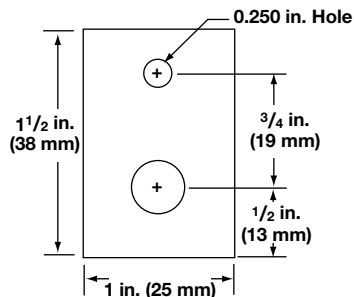

A 1 1/2 in. (38 mm) x 1 in. (25 mm) wide x 16 gauge stainless steel bracket with one element hole and one mounting hole 1/2 in. (13 mm) from end.

To order, specify **single leg bracket**.

Locator Washers

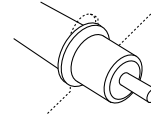

Stainless steel locator washers retain the heated area of the sheath in the work zone, while allowing for expansion and contraction during cycling.

To order, specify **locator washer**, along with dimension from the heater's end.

Mounting Collars

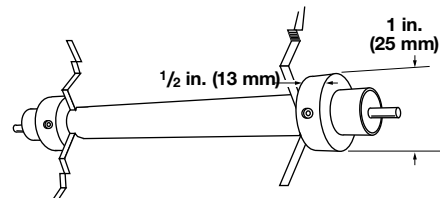

Plated steel mounting collars secure the heater sheath with set screws to serve as adjustable stops for through-the-wall mounting. Collars are shipped in bulk.

To order, specify **mounting collars**.

Tubular Heaters

WATROD Single/Double-Ended Heaters

Mounting Methods (Continued)

Threaded Bulkheads

A threaded bushing with flange on the heater sheath provides rigid, leak-proof mounting through the walls of tanks. A gasket, plated steel washer and hex nut are included. The threaded end of the bushing is flush with the sheath's end unless otherwise specified. Threaded bulkheads are available in brass, steel or stainless steel as indicated in the table.

To order, specify **threaded bulkheads** and the specifications from the table.

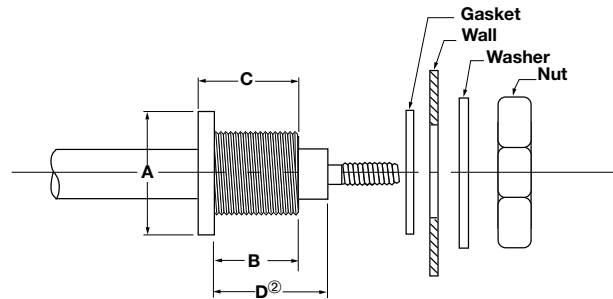

Threaded Bulkhead Specifications

Element Diameter in. (mm)	Material	Thread Size	A ① Flange Size/Style		B Threaded Length		C Overall Length	
			in.	(mm)	in.	(mm)	in.	(mm)
0.260 (6.6)	Brass	1/2 - 20 UNF	3/4	Round (19.0)	5/8	(15.9)	3/4	(19.0)
0.260 (6.6)	SS	1/2 - 20 UNF	3/4	Round (19.0)	5/8	(15.9)	3/4	(19.0)
0.315 (8.0)	Brass	1/2 - 20 UNF	3/4	Round (19.0)	5/8	(15.9)	3/4	(19.0)
0.315 (8.0)	Steel	1/2 - 20 UNF	3/4	Hex (19.0)	3/4	(19.0)	15/16	(23.8)
0.315 (8.0)	SS	1/2 - 20 UNF	3/4	Round (19.0)	3/4	(19.0)	27/32	(21.4)
0.375 (9.5)	Brass	1/2 - 20 UNF	3/4	Round (19.0)	5/8	(15.9)	3/4	(19.0)
0.375 (9.5)	Steel	1/2 - 20 UNF	3/4	Hex (19.0)	3/4	(19.0)	15/16	(23.8)
0.375 (9.5)	SS	1/2 - 20 UNF	3/4	Round (19.0)	3/4	(19.0)	27/32	(21.4)
0.430 (10.9)	Brass	5/8 - 18 UNF	7/8	Hex (22.2)	3/4	(19.0)	15/16	(23.8)
0.430 (10.9)	Steel	5/8 - 18 UNF	7/8	Round (22.2)	3/4	(19.0)	15/16	(23.8)
0.430 (10.9)	SS	5/8 - 18 UNF	1	Round (25.0)	3/4	(19.0)	15/16	(23.8)
0.475 (12.1)	Brass	5/8 - 18 UNF	7/8	Round (22.2)	3/4	(19.0)	15/16	(23.8)
0.475 (12.1)	Steel	5/8 - 18 UNF	1	Round (25.0)	1	(25.0)	1 1/8	(28.6)
0.475 (12.1)	SS	5/8 - 18 UNF	1	Round (25.0)	3/4	(19.0)	15/16	(23.8)

① Designates the dimension across flats for hex flange style and outside diameter for round flange style.

② Equal to "B" dimension unless otherwise specified.

Tubular Heaters



Extended Capabilities For WATROD Single/Double-Ended Heaters

Options

Terminal Enclosures

General purpose terminal enclosures, without thermostats, are standard on all screw plug immersion heaters. To meet specific application requirements, Watlow offers the following optional terminal enclosures:

- General purpose with single or double pole thermostat
- Moisture-resistant or corrosion resistant—available with optional single or double pole thermostat
- Explosion-resistant class 1, groups B, C and D explosion resistant—available with optional single or double-pole thermostat.
- Explosion and moisture-resistant combination—available with optional single- or double-pole thermostat

Zoned Heaters

Multiple zone heaters with up to (5) zones are available.

Features and Benefits

Standard sheath materials

- Optional materials available which include titanium, alloy 20, Hastelloy C276, 321 SS and alloy 400

Specifications

Double-Ended



Single-Ended



Element Diameters in. (mm) and Surface Area per Linear in ² (cm ²) Diameter Tolerance ± 0.005 in. (0.13 mm)	Double-Ended		Single-Ended					
	Dia. in. mm	in ² cm ²	Dia. (mm)	cm ²	Dia. in. mm	in ² cm ²	Dia. (mm)	cm ²
	0.490	1.539	(12.45)	(9.93)	0.490	1.539	(12.45)	(9.930)
Sheath Materials Max. Operating Temperature	Extended: Alloy 400 Titanium	Contact Watlow Contact Watlow			Extended: Alloy 600 Steel	1800°F (980°C) 750°F (400°C)		
Sheath Length By Diameter in. (mm)	Dia.	Sheath Length (in.)	Dia. (mm)	Sheath Length (mm)	Dia.	Sheath Length (in.)	Dia. (mm)	Sheath Length (mm)
	Extended: 0.490	11 to 265	(12.45)	(280 to 6731)	Extended: 0.490	11 to 125	(12.45)	(280 to 3175)
Max. Voltage/Amperage By Dia. in. (mm)	Dia.	Volts	Ampere	Dia.	Volts	Ampere	Dia.	Volts
	0.490 (12.45)	600VAC	40	0.490 (12.45)	480VAC	30	0.490 (12.45)	480VAC
Ohms Per Heated Inch By Dia.	Dia.	Min.	Max.	Dia.	Min.	Max.	Dia.	Min.
	0.490	0.035Ω	21Ω	0.490	0.150Ω	24Ω	0.490	0.150Ω

Extended Capabilities For WATROD Single/Double-Ended Heaters

Bend Formations

Figure 33

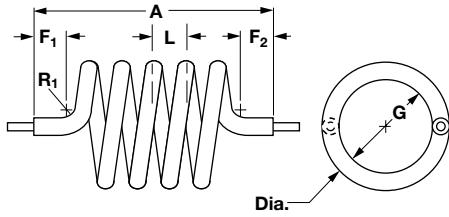

$$SL = [(G + \text{Dia.}) (3.14) (\text{Number of } 360^\circ\text{'s}) + F_1 + F_2]$$

(For pricing, contact Watlow)

Figure 34

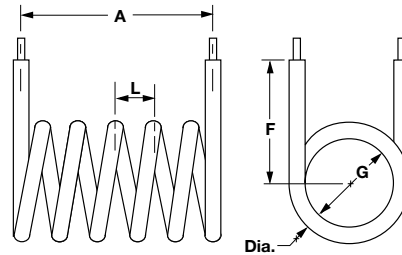

$$SL = [(G + \text{Dia.}) (3.14) (\text{Number of } 360^\circ\text{'s}) + 2F]$$

(For pricing, contact Watlow)

Figure 35

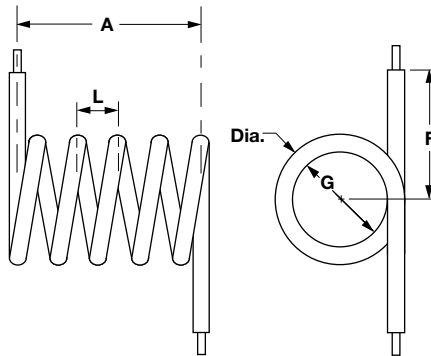

$$SL = [(G + \text{Dia.}) (3.14) (\text{Number of } 360^\circ\text{'s}) + 2F]$$

(For pricing, contact Watlow)

Figure 36

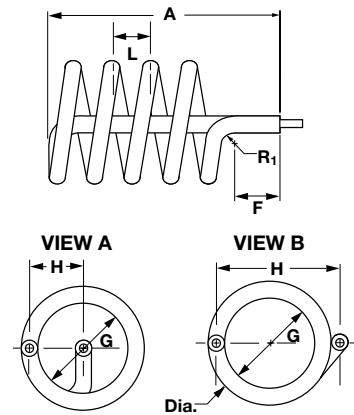

$$SL = [(G + \text{Dia.}) (3.14) (\text{Number of } 360^\circ\text{'s}) + (G \div 2) + A + F]$$

(For pricing, contact Watlow)

Extended Capabilities For WATROD Single/Double-Ended Heaters

Mounting Methods

Threaded Bulkheads

A threaded bushing with flange on the heater sheath provides rigid, leak-proof mounting through the walls of tanks. A gasket, plated steel washer and hex nut are included. The threaded end of the bushing is flush with the sheath's end unless otherwise specified. Threaded bulkheads are available in brass, steel or stainless steel as indicated in the table.

To order, specify **threaded bulkheads** and the specifications from the table.

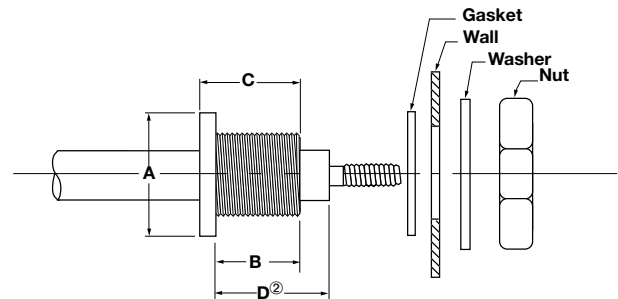

Threaded Bulkhead Specifications

Element Diameter		Material	Thread Size	A ① Flange Size/Style		B Threaded Length		C Overall Length	
in.	(mm)			in.	(mm)	in.	(mm)	in.	(mm)
0.260	(6.6)	Steel	1/2 - 20 UNF	3/4 Hex	(19.0)	5/8	(15.9)	3/4	(19.0)
0.430	(10.9)	Titanium	5/8 - 18 UNF	1 Round	(25.0)	3/4	(19.0)	15/16	(23.8)
0.490	(12.5)	Brass	3/4 - 16 UNF	1 Round	(25.0)	3/4	(19.0)	1	(25.0)
0.490	(12.5)	Steel	3/4 - 16 UNF	1 Hex	(25.0)	3/4	(19.0)	1	(25.0)
0.490	(12.5)	SS	3/4 - 16 UNF	1 Round	(25.0)	3/4	(19.0)	1	(25.0)

① Designates the dimension across flats for hex flange style and outside diameter for round flange style.

② Equal to "B" dimension unless otherwise specified.

Tubular Heaters

WATROD Single/Double-Ended Heaters

Double-Ended WATROD

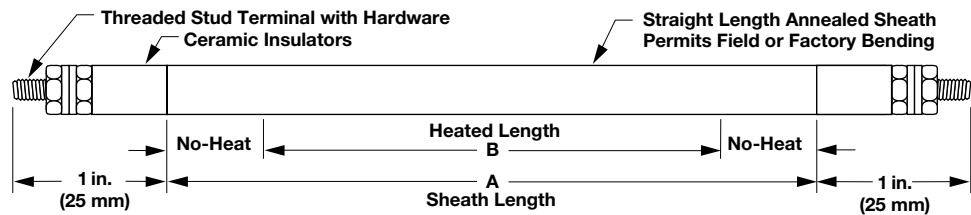

WATROD Description	Sheath A Dimension		Heated B Dimension		Watts	Part Number			Est. Net Wt.	
	in.	(mm)	in.	(mm)		120VAC	240VAC	480VAC	lbs	(kg)

Applications: Medium-Weight, Non-Circulating Oil, Heat-Transfer Oil

15 W/in² 0.475 in. Dia. Steel (2.3 W/cm²) (12 mm)	29 ⁷ / ₈	(758.8)	22 ³ / ₈	(568.4)	500		RGSS29R10S		1.0	(0.5)
	38 ³ / ₈	(974.7)	29 ⁷ / ₈	(758.8)	667		RGSS38G10S	RGSS38G11S	1.3	(0.6)
	44 ³ / ₄	(1137.0)	37 ¹ / ₄	(946.0)	833		RGSS44G10S	RGSS44G11S	1.7	(0.8)
	53 ³ / ₈	(1355.7)	44 ³ / ₄	(1137.0)	1000		RGSS53G10S	RGSS53G11S	1.9	(0.9)
	68 ³ / ₈	(1736.7)	59 ⁵ / ₈	(1514.4)	1333		RGSS68G10S	RGSS68G11S	2.1	(1.0)
	83 ³ / ₈	(2117.7)	74 ¹ / ₂	(1892.0)	1667		RGSS83G10S	RGSS83G11S	2.5	(1.1)
	98 ³ / ₈	(2498.7)	89 ¹ / ₂	(2273.0)	2000		RGSS98G10S	RGSS98G11S	3.0	(1.4)
	120 ³ / ₈	(3057.5)	111 ⁷ / ₈	(2841.6)	2500		RGSS120G10S ①	RGSS120G11S ①	3.9	(1.8)
142 ⁷ / ₈	(3629.1)	134 ¹ / ₄	(3410.0)	3000		RGSS142R10S ①	RGSS142R11S ①	4.1	(1.9)	

Application: Air Heating

20 W/in² 0.430 in. Dia. Alloy 840 (3.1 W/cm²) (10.9 mm)	48 ³ / ₄	(1238.0)	38 ³ / ₄	(984.0)	1000		RCN48N10S	RCN48N11S	1.0	(0.5)
	58 ³ / ₄	(1492.0)	48 ³ / ₄	(1238.0)	1250		RCN58N10S	RCN58N11S	1.1	(0.5)
	73 ³ / ₄	(1873.0)	63 ³ / ₄	(1619.0)	1667			RCN73N11S	1.4	(0.7)
	91 ³ / ₄	(2330.0)	81 ³ / ₄	(2076.0)	2083			RCN91N11S	1.7	(0.8)

Applications: Caustic Solutions, Air Heating

23 W/in² 0.315 in. Dia. Alloy 800 (3.6 W/cm²) (8 mm)	29	(737.0)	22	(559.0)	500	RBN291S			0.4	(0.2)
	40	(1016.0)	33	(839.0)	750	RBN401S			0.5	(0.3)
	51	(1296.0)	44	(1118.0)	1000	RBN511S			0.7	(0.4)
23 W/in² 0.475 in. Dia. Alloy 800 (3.6 W/cm²) (12 mm)	39	(991.0)	27	(686.0)	1000	RGNA391S	RGNA3910S	RGNA3911S	1.2	(0.6)
	54	(1372.0)	42	(1067.0)	1500		RGNA5410S	RGNA5411S	1.6	(0.8)
	69	(1753.0)	57	(1448.0)	2000		RGNA6910S	RGNA6911S	2.1	(1.0)
	84	(2134.0)	72	(1829.0)	2500		RGNA8410S	RGNA8411S	2.5	(1.2)
	99	(2515.0)	87	(2210.0)	3000		RGNA9910S	RGNA9911S	3.0	(1.4)
	106	(2692.0)	94	(2388.0)	2778			RGNA10611S ①	3.2	(1.5)
	132	(3353.0)	120	(3048.0)	4167		RGNA13210S ①	RGNA13211S ①	4.0	(1.8)
157	(3988.0)	145	(3683.0)	5000		RGNA15710S ①	RGNA15711S ①	4.7	(2.2)	

Applications: Light Oils, Greases, Heat-Transfer Oils

23 W/in² 0.315 in. Dia. Steel (3.6 W/cm²) (8 mm)	16	(406.0)	12	(305.0)	250	RBS161S	RBS1610S		0.2	(0.1)
	18	(457.0)	14	(356.0)	250	RBS181S			0.3	(0.2)
	21	(533.0)	17	(432.0)	350	RBS211S	RBS2110S		0.3	(0.2)
	23 ³ / ₈	(593.7)	19 ³ / ₈	(492.1)	375	RBS23G1S			0.3	(0.2)
	28 ⁷ / ₈	(733.4)	24 ⁷ / ₈	(631.8)	500	RBS28R1S			0.4	(0.2)
	29	(737.0)	24	(610.0)	500	RBS291S	RBS2910S		0.4	(0.2)
	42	(1067.0)	37	(940.0)	750	RBS421S	RBS4210S		0.6	(0.3)
	54	(1372.0)	49	(1245.0)	1000	RBS541S	RBS5410S		0.7	(0.4)
	77	(1956.0)	72	(1829.0)	1500	RBS771S	RBS7710S		1.0	(0.5)

CONTINUED

RAPID SHIP

Truck Shipment only

• Next day shipment up to 15 pieces

• ① - Manufacturing lead times

Tubular Heaters

WATROD Single/Double-Ended Heaters

Double-Ended WATROD (Continued)

WATROD Description	Sheath A Dimension		Heated B Dimension		Watts	Part Number			Est. Net Wt.	
	in.	(mm)	in.	(mm)		120VAC	240VAC	480VAC	lbs	(kg)
23 W/in² 0.475 in. Dia. Steel (3.6 W/cm²) (12 mm)	23	(584)	14	(356)	500	RGS231S	RGS2310S		0.7	(0.4)
	31	(787)	22	(559)	750	RGS311S	RGS3110S		1.0	(0.5)
	39	(991)	27	(686)	1000	RGS391S	RGS3910S	RGS3911S	1.2	(0.6)
	45	(1143)	36	(914)	1250	RGS451S	RGS4510S		1.4	(0.7)
	54	(1372)	42	(1067)	1500	RGS541S	RGS5410S	RGS5411S	1.6	(0.8)
	69	(1753)	57	(1448)	2000	RGS691S	RGS6910S	RGS6911S	2.1	(1.0)
	84	(2134)	72	(1829)	2500	RGS841S	RGS8410S	RGS8411S	2.5	(1.2)
	99	(2515)	87	(2210)	3000		RGS9910S	RGS9911S	3.0	(1.4)
	106	(2692)	90	(2286)	2778			RGS10611S ①	3.2	(1.5)
	132	(3353)	120	(3048)	4167		RGS13210S ①	RGS13211S ①	4.0	(1.8)
	144	(3658)	128	(3251)	3889			RGS14411S ①	4.3	(2.0)
	157	(3988)	145	(3683)	5000		RGS15710S ①	RGS15711S ①	4.7	(2.2)

Applications: Light Oils, Greases, Heat-Transfer Oils

Application: Air Heating

30 W/in² 0.260 in. Dia. Alloy 840 (4.7 W/cm²) (6.6 mm)	20	(508)	15	(381)	400		RAN2010S		0.2	(0.1)	
	25	(635)	20	(508)	500		RAN2510S		0.3	(0.2)	
	30	(762)	25	(635)	600		RAN3010S		0.3	(0.2)	
	35	(889)	30	(762)	800		RAN3510S		0.4	(0.2)	
	40	(1016)	35	(889)	900		RAN4010S		0.4	(0.2)	
	45	(1143)	40	(1016)	1000		RAN4510S		0.5	(0.3)	
	50	(1270)	45	(1143)	1200		RAN5010S		0.5	(0.3)	
	55	(1397)	50	(1270)	1200		RAN5510S		0.6	(0.3)	
	60	(1524)	55	(1397)	1400		RAN6010S		0.6	(0.3)	
	65	(1651)	60	(1524)	1600		RAN6510S		0.7	(0.4)	
	70	(1778)	65	(1651)	1800		RAN7010S		0.7	(0.4)	
	75	(1905)	70	(1778)	1800		RAN7510S		0.8	(0.4)	
	80	(2032)	75	(1905)	2000		RAN8010S		0.8	(0.4)	
	30 W/in² 0.315 in. Dia. Alloy 840 (4.7 W/cm²) (8 mm)	15	(381)	10	(254)	300		RBN1510S		0.2	(0.1)
		20	(508)	15	(381)	400		RBN2010S		0.3	(0.2)
25		(635)	20	(508)	600		RBN2510S		0.4	(0.2)	
30		(762)	25	(635)	800		RBN3010S		0.4	(0.2)	
35		(889)	30	(762)	900		RBN3510S		0.5	(0.3)	
40		(1016)	35	(889)	1000		RBN4010S		0.5	(0.3)	
45		(1143)	40	(1016)	1200		RBN4510S		0.6	(0.3)	
50		(1270)	45	(1143)	1400		RBN5010S		0.7	(0.4)	
55		(1397)	50	(1270)	1600		RBN5510S		0.7	(0.4)	
60		(1524)	55	(1397)	1800		RBN6010S		0.8	(0.4)	
65		(1651)	60	(1524)	1800		RBN6510S		0.8	(0.4)	
70		(1778)	65	(1651)	2000		RBN7010S		0.9	(0.5)	
75		(1905)	70	(1778)	2200		RBN7510S		1.0	(0.5)	
80		(2032)	75	(1905)	2400		RBN8010S		1.0	(0.5)	
90		(2286)	85	(2159)	2600		RBN9010S		1.2	(0.6)	
100	(2540)	95	(2413)	3000		RBN10010S		1.3	(0.6)		

CONTINUED

RAPID SHIP

- Next day shipment up to 15 pieces
- ① - Manufacturing lead times

Truck Shipment only

Tubular Heaters

WATROD Single/Double-Ended Heaters

Double-Ended WATROD (Continued)

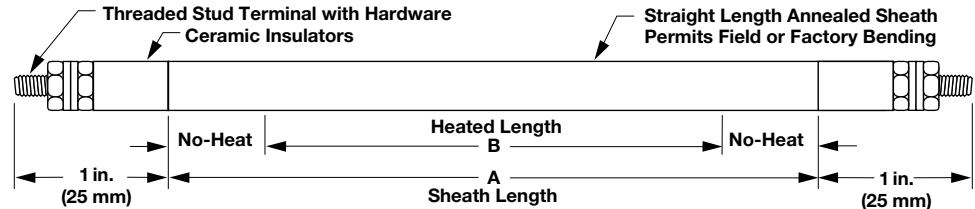

WATROD Description	Sheath A Dimension		Heated B Dimension		Watts	Part Number			Est. Net Wt.	
	in.	(mm)	in.	(mm)		120VAC	240VAC	480VAC	lbs	(kg)

Application: Air Heating

30 W/in² 0.430 in. Dia. Alloy 840 (4.7 W/cm²) (10.9 mm)	15	(381.0)	10	(254.0)	400		RCN1510S		0.3	(0.2)
	20	(508.0)	15	(381.0)	600		RCN2010S		0.4	(0.2)
	25	(635.0)	20	(508.0)	800		RCN2510S		0.5	(0.3)
	30	(762.0)	25	(635.0)	1000		RCN3010S		0.6	(0.3)
	35	(889.0)	30	(762.0)	1200		RCN3510S		0.7	(0.4)
	40	(1016.0)	35	(889.0)	1400		RCN4010S	RCNX48N11S	0.8	(0.4)
	48 ^{3/4}	(1238.0)	38 ^{3/4}	(984.0)	1500		RCNX48N10S		1.0	(0.5)
	45	(1143.0)	40	(1016.0)	1600		RCN4510S		0.9	(0.5)
	50	(1270.0)	45	(1143.0)	1800		RCN5010S		1.0	(0.5)
	58 ^{3/4}	(1492.0)	48 ^{3/4}	(1238.0)	1917		RCNX58N10S	RCNX58N11S	1.1	(0.5)
	55	(1397.0)	50	(1270.0)	2000		RCN5510S		1.0	(0.5)
	60	(1524.0)	55	(1397.0)	2200		RCN6010S		1.1	(0.5)
	65	(1651.0)	60	(1524.0)	2400		RCN6510S		1.2	(0.6)
	73 ^{3/4}	(1873.0)	63 ^{3/4}	(1619.0)	2500			RCNX73N11S	1.4	(0.7)
	70	(1778.0)	65	(1651.0)	2600		RCN7010S		1.3	(0.6)
	75	(1905.0)	70	(1778.0)	2800		RCN7510S		1.4	(0.7)
	80	(2032.0)	75	(1905.0)	3000		RCN8010S		1.5	(0.7)
	91 ^{3/4}	(2331.0)	81 ^{3/4}	(2077.0)	3167			RCNX91N11S	1.7	(0.8)
90	(2286.0)	85	(2159.0)	3500		RCN9010S		1.7	(0.8)	
100	(2540.0)	95	(2413.0)	4000		RCN10010S ①		1.9	(0.9)	
110	(2794.0)	105	(2667.0)	4500		RCN11010S ①		2.1	(1.0)	
120	(3048.0)	115	(2921.0)	5000		RCN12010S ①		2.3	(1.1)	

Application: Radiant Heating

40 W/in² 0.375 in. Dia. Alloy 800 (6.2 W/cm²) (9.5 mm)	10 ^{1/4}	(260.0)	7 ^{1/4}	(184.0)	400	RDN10E1S			0.2	(0.1)
	16 ^{5/8}	(422.1)	13 ^{5/8}	(346.1)	650	RDN16L1S			0.3	(0.2)
	21 ^{1/16}	(535.0)	16 ^{13/16}	(427.0)	800	RDN21B1S	RDN21B10S		0.4	(0.2)
	27 ^{1/8}	(689.0)	22 ^{7/8}	(581.0)	1100	RDN27C1S	RDN27C10S		0.5	(0.3)
	32 ^{1/8}	(816.0)	27 ^{7/8}	(708.0)	1300		RDN32C10S	RDN32C11S	0.6	(0.3)
	42 ^{7/8}	(1089.0)	38 ^{5/8}	(981.1)	1800		RDN42R10S	RDN42R11S	0.8	(0.4)
	57 ^{1/2}	(1461.0)	53 ^{1/4}	(1353.0)	2500		RDN57J10S	RDN57J11S	1.1	(0.5)
	69 ^{1/4}	(1759.0)	65	(1651.0)	3000		RDN69E10S	RDN69E11S	1.3	(0.6)
	81 ^{1/4}	(2064.0)	77	(1956.0)	3600		RDN81E10S	RDN81E11S	1.6	(0.8)
	109 ^{1/4}	(2775.0)	105	(2667.0)	4000		RDN109E10S ①		2.1	(1.0)
	134 ^{1/2}	(3416.0)	127 ^{3/4}	(3245.0)	5000		RDN134J10S ①		2.6	(1.2)
	153 ^{3/8}	(3895.7)	145 ^{7/8}	(3705.2)	5500		RDN153R10S ①		2.9	(1.4)
	179 ^{1/4}	(4553.0)	171 ^{1/4}	(4350.0)	6500		RDN179E10S ①		3.4	(1.6)

CONTINUED

RAPID SHIP

Truck Shipment only

• Next day shipment up to 15 pieces

• ① - Manufacturing lead times

Tubular Heaters

WATROD Single/Double-Ended Heaters

Double-Ended WATROD (Continued)

Special 208VAC and 277VAC Voltages

WATROD Description	Sheath A Dimension		Heated B Dimension		Watts	Part Number		Est. Net Wt.	
	in.	(mm)	in.	(mm)		208VAC	277VAC	lbs	(kg)

Application: Radiant Heating

40 W/in ² 0.375 in. Dia. Alloy 800	21 ¹ / ₁₆	(535)	16 ¹³ / ₁₆	(427)	800	RDN21B2S ^①	RDN21B4S ^①	0.4	(0.2)
	27 ¹ / ₈	(689)	22 ⁷ / ₈	(581)	1100	RDN27C2S ^①	RDN27C4S ^①	0.5	(0.3)
	42 ⁷ / ₈	(1089)	38 ⁵ / ₈	(981)	1800	RDN42R2S ^①	RDN42R4S ^①	0.8	(0.4)
(6.2 W/cm ²) (9.5 mm)	57 ¹ / ₂	(1461)	53 ¹ / ₄	(1353)	2500	RDN57J2S ^①	RDN57J4S ^①	1.1	(0.5)
	69 ¹ / ₄	(1759)	65	(1651)	3000	RDN69E2S ^①	RDN69E4S ^①	1.3	(0.6)
	81 ¹ / ₄	(2064)	77	(1956)	3600	RDN81E2S ^①	RDN81E4S ^①	1.6	(0.8)

WATROD Description	Sheath A Dimension		Heated B Dimension		Watts	Part Number			Est. Net Wt.	
	in.	(mm)	in.	(mm)		120VAC	240VAC	480VAC	lbs	(kg)

Application: Process Water

48 W/in ² 0.475 in. Dia. Alloy 800 (7.4 W/cm ²) (12 mm)	23	(584)	14	(356)	1000	RGN231S	RGN2310S	RGN2311S	0.7	(0.4)
	30	(762)	21	(533)	1500	RGN301S	RGN3010S	RGN3011S	0.9	(0.5)
	39	(991)	27	(686)	2000	RGN391S	RGN3910S	RGN3911S	1.2	(0.6)
	44	(1118)	35	(889)	2500	RGN441S	RGN4410S	RGN4411S	1.3	(0.6)
	54	(1372)	42	(1067)	3000		RGN5410S	RGN5411S	1.6	(0.8)
	69	(1753)	57	(1448)	4000		RGN6910S	RGN6911S	2.1	(1.0)
	84	(2134)	72	(1829)	5000		RGN8410S	RGN8411S	2.5	(1.2)
	92	(2337)	76	(1930)	5556			RGN9211S	2.8	(1.3)
	99	(2515)	87	(2210)	6000		RGN9910S	RGN9911S	3.0	(1.4)
	149	(3785)	133	(3378)	9722			RGN14911S ^①	4.5	(2.1)

Application: Hot Runner Molds (Manifolds)

60 W/in ² 0.315 in. Dia. 316 SS (9.3 W/cm ²) (8 mm)	35	(889)	25	(635)	1500		RBR3510S		0.2	(0.1)
	44	(1118)	34	(864)	2000		RBR4410S		0.3	(0.2)
	52	(1321)	42	(1067)	2500		RBR5210S		0.3	(0.2)
	60	(1524)	50	(1270)	3000		RBR6010S		0.4	(0.2)
	69	(1753)	59	(1499)	3500		RBR6910S		0.4	(0.2)
	77	(1956)	67	(1702)	4000		RBR7710S		0.5	(0.3)
	85	(2159)	75	(1905)	4500		RBR8510S		0.6	(0.3)

Applications: Deionized Water, Demineralized Water

60 W/in ² 0.475 in. Dia. 316 SS (9.3 W/cm ²) (12 mm)	20	(508)	11	(279)	1000	RGR201S	RGR2010S	RGR2011S	0.6	(0.3)
	26	(660)	17	(432)	1500	RGR261S	RGR2610S	RGR2611S	0.8	(0.4)
	34	(864)	22	(559)	2000		RGR3410S	RGR3411S	1.0	(0.5)
	40	(1016)	28	(711)	2500		RGR4010S	RGR4011S	1.2	(0.6)
	47	(1194)	31	(787)	2778			RGR4711S	1.4	(0.7)
	46	(1168)	34	(864)	3000		RGR4610S	RGR4611S	1.4	(0.7)
	57	(1448)	45	(1143)	4000		RGR5710S	RGR5711S	1.7	(0.8)
	68	(1727)	56	(1422)	5000		RGR6810S	RGR6811S	2.1	(1.0)
	79	(2007)	67	(1702)	6000		RGR7910S	RGR7911S	2.4	(1.1)
	105	(2667)	93	(2362)	8333			RGR10511S ^①	3.2	(1.5)

CONTINUED

RAPID SHIP

Truck Shipment only

- Next day shipment up to 15 pieces
- ① - Manufacturing lead times

Tubular Heaters

WATROD Single/Double-Ended Heaters

Single-Ended WATROD

Application Hints

The single-ended WATROD heater's construction limits its usefulness in some applications. The following are some guides to follow when considering a single-ended WATROD.

- When single-ended termination simplifies application wiring.
- The application requires lower wattage or a smaller package.
- Do not locate the end of the heated length within a bend, unless the radius is 3 in. (75 mm) or more. Field bending is not recommended.
- Bending is limited to bend Figures 1, 6, 22 and 28 (see pages 67 to 72 for details).
- Ensure termination temperatures do not exceed 390°F (200°C) or the seal's maximum rating.
- Keep terminations clean, dry and tight.

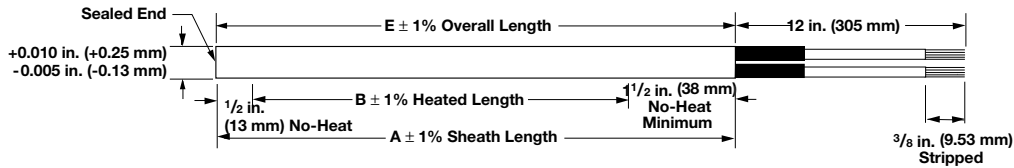

Tubular Heaters

WATROD Double-Ended Heaters

High-Temperature Tubular Heaters

Watlow manufactures high-temperature tubular heaters to bridge the gap between standard tubular heaters and Watlow MULTICELL™ heaters. This tubular is well suited for process air heating applications in excess of 1300°F (704°C), resulting in a maximum sheath temperature of 1800°F (983°C). Controlled lab testing between the new design and current tubular designs show an increase in life of approximately 50 percent.

The high-temperature tubular consists of an engineered tubing with an outer sheath of alloy 600 and a special internal construction. The outer sheath offers high temperature capabilities, reduced oxidation as well as corrosion resistance.

The tubular offering is available in 0.430 and 0.375 inch diameters that are configurable either as formed tubulars or process heaters. The heaters can also be welded to flanges and plates for mounting purposes. Maximum sheath length available is 275 inches for the 0.430 inch and 0.375 inch diameters. The factory should be contacted for longer sheath lengths.

Features and Benefits

Alloy 600 sheath material and a special internal construction

- Assures high temperature performance and corrosion protection in tough applications

0.430 inch diameters*

- Allows heater to be configured to existing tubular designs that may be experiencing short life

***Note: 0.375 diameters are available in Watlow's extended capabilities, contact your Watlow representative for details.**

Dual-ended termination

- Installs into flanges and screw plugs similarly to standard product configurations

Bendable in standard formations

- Makes the heater easy to apply in a wide variety of applications



Typical Applications

- High temperature ovens and furnaces
- Radiant heating
- Drying
- Environmental—VOC abatement
- Process air heating: duct heaters, circulation heaters
- Vacuum applications
- Flue gas cleaning (desulphurization)
- Fluidized beds

Tubular Heaters

WATROD Double-Ended Heaters

High-Temperature Tubular Heaters

Sheath Temperature Versus Oven Temperature at Various Watt Densities

This chart is used to verify the correct watt density for an oven application assuming no air flow. To use the chart, first select the oven process temperature on the X axis, using the chosen watt density read the sheath temperature rise above oven temperature from the Y axis. This number should then be added to oven temperature. If this number is greater than 1800°F (982°C), a lower watt density should be chosen.

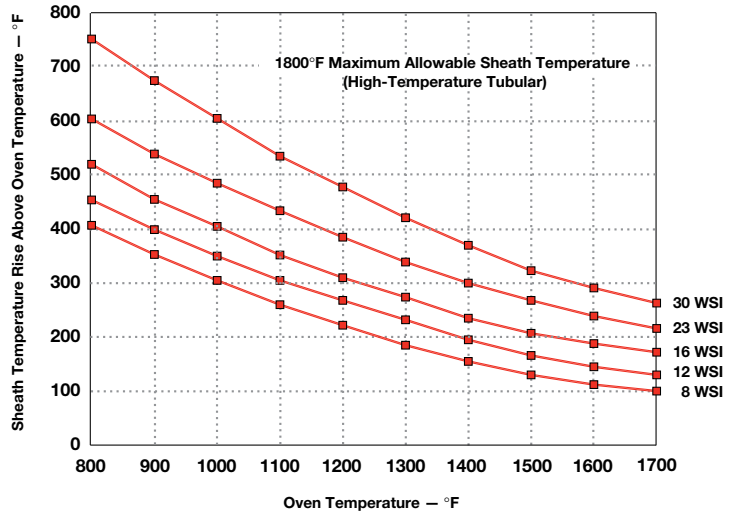

Heater Life Estimate Service

Watlow now provides an industry first service with the offering of the high-temperature tubular. By providing operating parameters, Watlow provides customers with the estimated life of the heater. To get this information, the following information should be provided:

- Heater voltage
- Heater wattage
- Heater diameter (0.430 or 0.375 in.)
- Heated length
- Bend configuration and dimensions (number of bends and radius)
- Application including process temperature
- Power switching device and cycle time (SCR, etc.)

High-Temperature Heater Comparisons

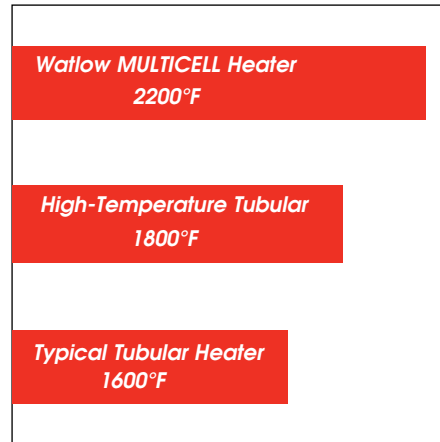

*Assuming normal design practices.

Tubular Heaters

EXTENDED
CAPABILITY

WATROD Single/Double-Ended Heaters

Extended Capabilities For MULTICOIL™ Tubular Heaters

The tubular element with multiple coils and/or thermocouples inside one sheath from Watlow answers the need for a versatile, innovative tubular heater. Watlow's patented method of packaging a thermocouple inside of a heater with one or more resistance coils, gives the ability to sense a heaters' internal temperature accurately, every time.

Moreover, this is the first tubular heater in the industry with three-phase capability. The three coil, three-phase heater will offer a compact package solution while delivering the full power required in a compact heater package. Previously three separate heaters would have been required to do the same job; therefore Watlow's MULTICOIL™ heater capabilities save money.

Performance Capabilities

- Watt densities up to 60 W/in² (9.3 W/cm²)
- Sheath temperatures up to 1600°F (870°C)
- 304 and 316 stainless steel sheath temperatures up to 1200°F (650°C)

Features and Benefits

Three-phase capability

- Results in one element versus three, lower amperage, reduced installation time and lower overall cost

Single-ended

- Allows for mounting in a 1/2 inch NPT or 3/4 inch NPT fitting with three-phase capability
- Sensor is not available

Multiple coil operations

- Reduces inventory by allowing dual voltage capability

Versatile forming capabilities

- Forms into many configurations

Internal construction with sensor

- Allows space savings because drilling and tapping of flange is unnecessary; plus, the interior thermocouple eliminates contamination buildup around the external sensing tip, reducing the possibility of false readings

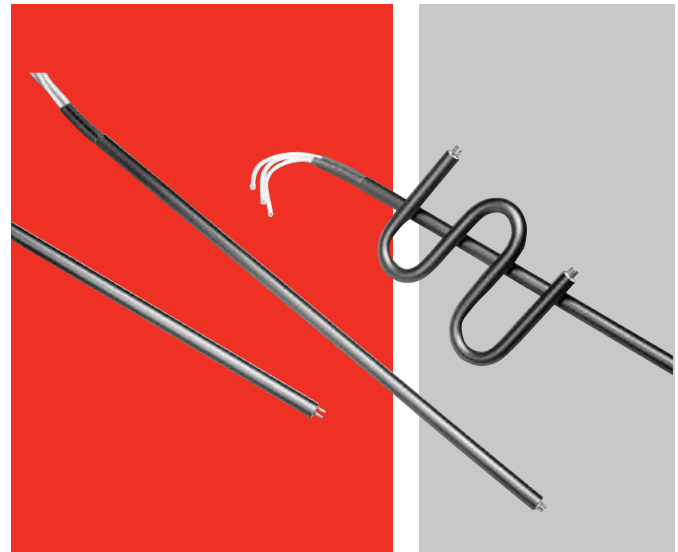

Typical Applications

- Foodservice
- Process
- Medical
- Milled groove
- Plastics
- Plating
- Oven heating
- Semiconductor

WATROD Single/Double-Ended Heaters

Extended Capabilities For MULTICOIL Tubular Heaters

Options

Option A

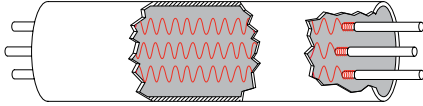

3-phase tubular, 0.475 and 0.490 inch diameter.

Option E

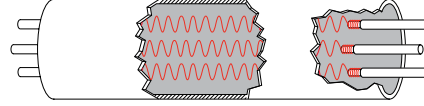

1-phase tubular with three different one phase circuits, 0.475 and 0.490 inch diameter.

Option C

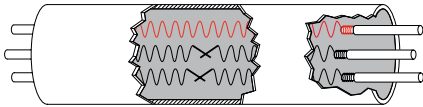

1-phase tubular with one resistance wire and two thermocouples, 0.475 and 0.490 inch diameter.

Option F

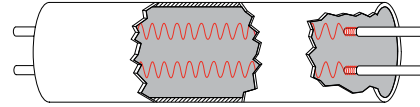

1-phase tubular with two resistance coils, 0.375, 0.430, 0.475 and 0.490 inch diameter.

Option D

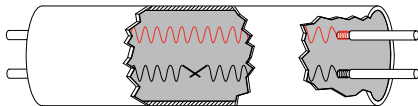

1-phase tubular with one resistance coil and one thermocouple, 0.375, 0.430, 0.475 and 0.490 inch diameter.

Specifications

Termination Styles

- Lead wires 392°F (200°C) Sil-A-Blend™ or 482°F (250°C) GGS.

Moisture Seals

Moisture seals are required, options include:

- Epoxy with temperature rating to 356°F (180°C). Typical applications include water/oil immersion.
- Lavacone with temperature rating to 221°F (105°C). Typical application includes air heating.
- High-temperature ceramic rated to 2800°F (1537.8°C).
- Contact your Watlow representative for other moisture seal options.

Mounting options

- Mounting brackets
- Locator washers
- Mounting collars
- Water-tight bulkheads

Maximum trim length

- 237 in. (6020 mm), heater designs with trim length greater than 120 in. (3048 mm) must be reviewed with your Watlow representative.

Sheath materials

- Alloy 600, 800, 840, 304 and 316 stainless steel, contact your Watlow representative for other sheath material options.

Internal thermocouple options

- Type K is used, contact your Watlow representative for Type J thermocouple options.

WATROD Single/Double-Ended Heaters

Extended Capabilities For Milled Groove Tubular Heaters

WATROD milled groove heaters are precision-formed and customized to your hot runner mold application. Even tight radius bends of 0.250 inch maintaining tolerances of ± 0.062 to ± 0.002 inch are possible. This capability not only allows you freedom to design for the optimum uniform heating pattern for your plastics process, but also guarantees quick and easy installation.

Simply send your groove dimensions in a detailed drawing or on CAD file. Depending on the formation requirements, the resulting CAD design will be transferred to either Watlow's CNC bending equipment or a highly skilled bending operator.

A variety of sheath materials are available including alloy 800, 304 stainless steel and 316 stainless steel; each offering unique advantages of long life in high temperature molds, rigidity to maintain shape during shipment and corrosion resistance.

Watlow not only delivers the heat fast to the process with efficient heat transfer, but guarantees the heater's fast delivery, too. While Watlow guarantees standard delivery within three to four weeks, tough delivery schedules are Watlow's specialty.

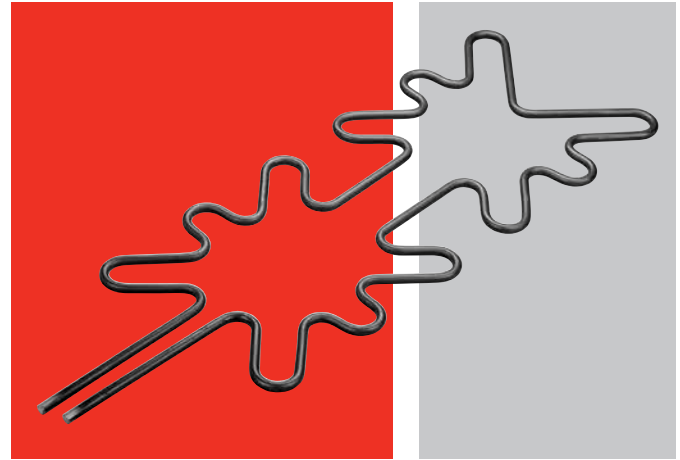

Features and Benefits

Precise conformity to customer specifications

- Ensures easy installation—bending tolerances as low as ± 0.002 in.

Common element diameters

- Includes 0.260, 0.315, 0.375 and 0.430 in. (6.6, 8, 9.5 and 10.9 mm) diameters

Alloy 800 sheath material

- Corrosion resistant, capable in high-temperature environments

304 stainless steel

- Excellent pliability, best choice for small bend radii

Superior resistance coil design

- Produces even heating

Threaded stud or lead wire termination as required

- Provides robust options for challenging environments

Typical Applications

- Hot runner molds
- Precise heat uniformity

WATROD Single/Double-Ended Heaters

Extended Capabilities For Milled Groove Tubular Heaters

Use the *Milled Groove Sheath Watt Density and Groove Fit* chart to find the recommended watt density or tightest groove fit. Optimum groove fit, without heat transfer cement, can be determined by plotting the intersect point between the required sheath watt density and the Delta temperature (T). If the Delta T is not known, simply subtract the mold temperature from the maximum 1000°F (540°C) sheath temperature. Any combination of watt density and groove fit which results in a Delta T below the recommended maximum will maximize heater life. Conversely, if the Delta T is greater, less heater life can be expected.

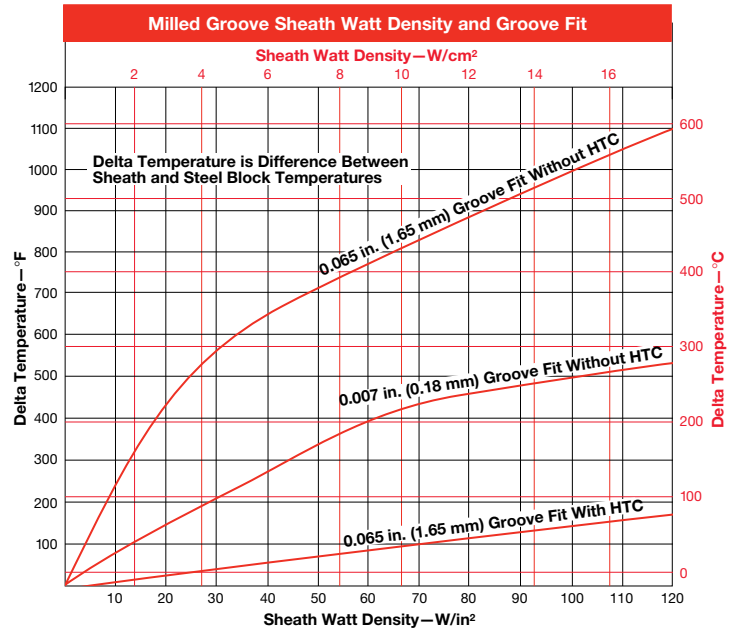

- Recommended maximum watt density = 40 to 70 W/in² (6.2 to 10.9 W/cm²)
- Recommended groove = 0.065 inch (1.65 mm) larger in diameter than sheath diameter and use heat transfer cement.
- Recommended heater sheath diameter = 0.315 in. (8 mm)
- Recommended maximum Delta T = 400°F (205°C)
- Maximum sheath temperature = 1000°F (540°C)
- Recommended sheath material = alloy 800

Tubular Heaters

FIREBAR® Single/Double-Ended Heaters

FIREBAR® heating elements provide added heating performance over standard round tubular heating elements—especially for immersion applications in petroleum based liquids requiring high kilowatts.

The FIREBAR's unique flat surface geometry packs more power in shorter elements and assemblies, along with a host of other performance improvements. These include:

- Minimizing coking and fluid degrading
- Enhancing the flow of fluid past the element's surface to carry heat from the sheath
- Improving heat transfer with a significantly larger boundary layer allowing much more liquid to flow up and across the sheath's surface

FIREBAR elements are available in single- and double-ended constructions with one inch or $\frac{5}{8}$ inch heights. These two configuration variables make it possible to use FIREBAR elements instead of round tubular elements in virtually all applications.

FINBAR™ is a special version of the one inch, single-ended FIREBAR. FINBAR is specially modified with fins to further increase surface area for air and gas heating applications. Details are contained in the *FINBAR* section, starting on page 112.

Double-Ended Performance Capabilities

One Inch

- Watt densities up to 120 W/in² (18.6 W/cm²)
- Sheath temperatures up to 1400°F (760°C)
- 304 stainless steel sheath temperatures up to 1200°F (650°C)
- Voltages up to 240VAC
- Amperages up to 48 amperes per heater or 16 amperes per coil

$\frac{5}{8}$ Inch

- Watt densities up to 90 W/in² (13.9 W/cm²)
- Alloy 800 sheath temperatures up to 1400°F (760°C)
- Voltages up to 240VAC
- Amperages up to 32 amperes per heater or 16 amperes per coil

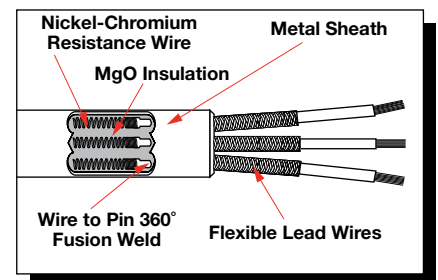
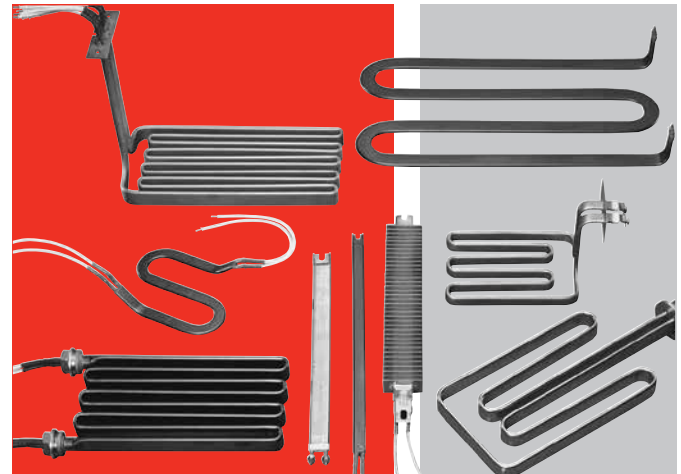

One Inch Double-Ended FIREBAR Element and Lead Configurations

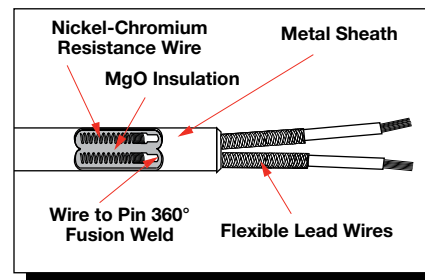

$\frac{5}{8}$ Inch Double-Ended FIREBAR Element and Lead Configurations

Single-Ended Performance Capabilities

One Inch

- Watt densities up to 60 W/in² (9.3 W/cm²)
- Alloy 800 sheath temperatures up to 1400°F (760°C)
- 304 stainless steel sheath temperatures up to 1200°F (650°C)
- Voltages up to 240VAC
- Amperages up to 48 amperes per heater or 16 amperes per coil

$\frac{5}{8}$ Inch

- Watt densities up to 80 W/in² (12.4 W/cm²)
- Alloy 800 sheath temperatures up to 1400°F (760°C)
- Voltages up to 240VAC
- Amperages up to 16 amperes per heater

Tubular Heaters

FIREBAR Double-Ended Heaters

Specifications

One Inch FIREBAR



5/8 Inch FIREBAR



Applications	Direct immersion; water, oils, etc. Clamp-on; hoppers, griddles Forced air heating (Also see FINBAR, page 112) Radiant heating	Direct immersion; water, oils, etc. Clamp-on; hoppers, griddles Forced air heating Radiant heating
Watt Density W/in ² (W/cm ²)	Stock: up to 90 (13.9) Made-to-Order (M-t-O): up to 120 (18.6)	Stock: up to 90 (13.9) Made-to-Order (M-t-O): up to 90 (13.9)
Surface Area Per Linear In. (cm)	2.3 in ² (14.8 cm ²)	1.52 in ² (9.80 cm ²)
Cross Section Height ± 0.015/0.010 in. (0.381/0.254 mm) Thickness ± 0.005/0.001 in. (0.127/0.025 mm)	1.010 (25.7) 0.235 (5.9)	0.650 (16.5) 0.235 (5.9)
Sheath Material—Max. Operating temperature	Stock: Alloy 800 1400°F (760°C) M-t-O: Alloy 800 1400°F (760°C) 304 SS 1200°F (650°C)	Stock: Alloy 800 1400°F (760°C) M-t-O: Alloy 800 1400°F (760°C) 304 SS 1200°F (650°C)
Sheath Length in. (mm)	Stock: 15 to 114 (381 to 2896) M-t-O: 11 to 180 (280 to 4572)	Stock: 15 to 51 (381 to 1295) M-t-O: 11 to 115 (280 to 2920)
Straightness Tolerance Major axis in./ft (cm/m): Minor axis in./ft (cm/m):	0.062 (0.52) 0.062 (0.52)	0.062 (0.52) 0.062 (0.52)
No-Heat Length	1 in. min., 12 in. max. (25/305 mm)	1 in. min., 12 in. max. (25/305 mm)
Max. Voltage—Amperage Max. Hipotential Max. Current Leakage Per Coil (cold) Max. Amperage Per Coil Phase(s) Resistance Coils	240VAC—48A 1480VAC 3mA 16A 1-ph parallel/series, 3-ph delta/wye 3 or 2	240VAC—32A 1480VAC 3mA 16A 1-ph parallel/series 2
Ohms/In./Unit ① Ohms/In./Coil ①	0.270Ω min.—2.833Ω max. 0.080Ω min.—8.500Ω max. per coil	0.040Ω min.—4.250Ω max. 0.080Ω min.—8.500Ω max. per coil
Terminations	Flexible lead wires Quick connect (spade) Screw lug (plate) Threaded stud	Flexible lead wires Quick connect (spade) Screw lug (plate) Threaded stud
Seals	Stock: Lavacone 221°F (105°C) M-t-O: Ceramic base 2800°F (1535°C) Silicone rubber 392°F (200°C) Lavacone 221°F (105°C) Epoxy resin 266/356°F (130/180°C)	Stock: Lavacone 221°F (105°C) M-t-O: Ceramic base 2800°F (1535°C) Silicone rubber 392°F (200°C) Lavacone 221°F (105°C) Epoxy resin 266/356°F (130/180°C)
Min. Axis Bending Radius in. (mm) (Do not field bend)	Major: 1 (25) Minor: 1/2 (13) 90° bend Minor: 3/8 (4) 180° bend	Major: 3/4 (19) Minor: 1/2 (13) 90° bend Minor: 3/8 (4) 180° bend
Mounting Options	Brackets (Type 1, 2 and 3) Threaded bulkhead or fitting	Brackets (Type 1, 2 and 3) Threaded bulkhead or fitting
Surface Finish Options	Bright anneal, passivation	Bright anneal, passivation
Agency Recognition	UL® Component recognition to 240VAC (File # E52951) CSA Component recognition to 240VAC (File # 31388)	UL® Component recognition to 240VAC (File # E52951) CSA Component recognition to 240VAC (File # 31388)

① Resistance values valid for three coil 1 in. (25 mm) FIREBAR only.

Tubular Heaters

FIREBAR Single-Ended Heaters

Specifications (Continued)

One Inch Single-Ended FIREBAR

5/8 Inch Single-Ended FIREBAR



Applications	Clamp-on; hoppers, griddles Forced or convection air heating (Also see FINBAR, page 112)	Clamp-on; hoppers, griddles Forced or convection air heating
Watt Density W/in ² (W/cm ²)	Stock: up to 40 (6.2) M-t-O: up to 60 (9.3)	Stock: up to 20 (3.1) M-t-O: up to 60 (12.4)
Surface Area Per Linear In. (cm)	2.3 in ² (14.8 cm ²)	1.52 in ² (9.80 cm ²)
Cross Section Height ± 0.015/0.010 in. (0.381/0.254 mm) Thickness ± 0.005/0.001 in. (0.127/0.025 mm)	1.010 (25.7) 0.235 (5.9)	0.650 (16.5) 0.235 (5.9)
Sheath Material—Max. Operating temperature	Stock: 304 SS 1200°F (650°C) M-t-O: Alloy 800 1400°F (760°C) 304 SS 1200°F (650°C)	Stock: Alloy 800 1400°F (760°C) M-t-O: Alloy 800 1400°F (760°C) 304 SS 1200°F (650°C)
Sheath Length in. (mm)	Stock: 11 to 46¼ (280 to 1175) M-t-O: 11 to 120 (280 to 3048)	Stock: 11½ to 52 (280 to 1321) M-t-O: 11 to 116 (280 to 2946)
Straightness Tolerance Major axis in./foot (cm/m): Minor axis in./foot (cm/m):	0.062 (0.52) 0.062 (0.52)	0.062 (0.52) 0.062 (0.52)
No-Heat Length Top Cold End Bottom (blunt end) Cold End	1 in. min., 12 in. max. (25/305 mm) 1 ph- 0.5 min., 2 in. max. (13/51 mm) 3 ph- 0.75 min., 2 in. max. (19/51 mm)	1 in. min., 12 in. max. (25/305 mm) Only available at 1.25 in. N/A
Max. Voltage—Amperage Max. Hipotential Max. Current Leakage (cold) Max. Amperage Per Coil Phase(s) Resistance Coils	240VAC—48A 1480VAC 3mA 16A 1-ph, 3-ph wye 3 or 1	240VAC—16A 1480VAC 3mA 16A 1-ph 1
Ohms/In./Unit	0.200Ω min.—14.00Ω max. ①	0.200Ω min.—14.00Ω max. ①
Terminations	Flexible lead wires Threaded stud Quick connect (spade) Screw lug (plate)	Flexible lead wires Quick connect (spade) Screw lug (plate)
Seals	Stock: Lavacone 221°F (105°C) M-t-O: Ceramic base 2800°F (1535°C) Silicone rubber 392°F (200°C) Lavacone 221°F (105°C) Epoxy resin 266/356°F (130/180°C)	Stock: Lavacone 221°F (105°C) M-t-O: Ceramic base 2800°F (1535°C) Silicone rubber 392°F (200°C) Lavacone 221°F (105°C) Epoxy resin 266/356°F (130/180°C)
Min. Axis Bending Radius in. (mm) (Do Not Field Bend)	Major: 1 (25) Minor: ½ (13) 90° bend Minor: 5/32 (4) 180° bend	Major: ¾ (19) Minor: ½ (13) 90° bend Minor: 5/32 (4) 180° bend
Mounting Options	Bracket (Type 2) Threaded bulkhead	Bracket (Type 2) Threaded bulkhead
Surface Finish Options	Bright anneal	Bright anneal
Optional Internal Thermocouple	—	—
Single-end Configuration	Stock: Slotted M-t-O: Slotted, sealed or welded	Stock: Slotted M-t-O: Slotted, sealed or welded
Agency Recognition	UL® Component recognition to 240VAC (File # E52951) CSA Component recognition to 240VAC (File # 31388)	UL® Component recognition to 240VAC (File # E52951) CSA Component recognition to 240VAC (File # 31388)

① Based on 1-phase, single voltage heater.

Tubular Heaters

FIREBAR Single/Double-Ended Heaters

Features and Benefits

One Inch Features and Benefits

Double-Ended

Streamline, 0.235 x 1.010 in. (5.9 x 25.6 mm) normal to flow dimension

- Reduces drag

70 percent greater surface area per linear inch compared to a 0.430 in. (11 mm) diameter round tubular heater

- Reduces watt density or packs more kilowatts in smaller bundles

Compacted MgO insulation

- Maximizes thermal conductivity and dielectric strength

Nickel-chromium resistance wires

- Precision wound

0.040 in. (1 mm) thick MgO walls

- Transfers heat more efficiently away from the resistance wire to the sheath and media—conducts heat out of the element faster

Three resistance coil design

- Configurable to either one- or three-phase power, readily adapts to a variety of electrical sources and wattage outputs

Lavacone seals

- Provides protection against humid storage conditions, moisture retardant to 221°F (105°C)

Single-Ended

Single-ended termination

- Simplifies wiring and installation

Streamline, 0.235 x 1.010 in. (5.9 x 25.6 mm) normal to flow dimension

- Reduces drag

70 percent greater surface area per linear inch

- Reduces watt density from that of the 0.430 in. (11 mm) diameter round tubular

Slotted end

- Provides installation ease in clamp-on applications

Lavacone seals

- Provides protection against humid storage conditions, moisture retardant to 221°F (105°C)

5/8 inch Features and Benefits

Double-Ended

Special sheath dimensions, 0.235 x 0.650 in. (5.9 x 16.5 mm)

- Results in a lower profile heater

10 percent greater surface area per linear inch

- Reduces watt density from that of the 0.430 in. (11 mm) diameter round tubular heater

0.040 in. (1 mm) thick MgO walls

- Transfers heat efficiently away from the resistance wire to the heated media—conducts heat out of the element faster

Lavacone seals

- Provides protection against humid storage conditions, moisture retardant to 221°F (105°C)

Single-Ended

Single-ended termination

- Simplifies wiring and installation

Special sheath dimensions, 0.235 x 0.650 in. (5.9 x 16.5 mm)

- Results in a lower profile heater for more wattage in a smaller package

Slotted end

- Provides installation ease in clamp-on applications

Lavacone seals

- Provides protection against humid storage conditions, moisture retardant to 221°F (105°C)

Tubular Heaters

FIREBAR Single/Double-Ended Heaters

Performance Features

FIREBAR's flat tubular element geometry produces performance features and benefits not possible with traditional round tubular technology. The following describes how and why the FIREBAR is functionally superior for many applications—especially those requiring large wattage with low watt density.

By using the FIREBAR element it will:

- Lower the element's watt density
- Reduce element size and keep the same watt density
- Increase element life by reducing sheath temperature

Flat Shape Produces Lower Sheath Temperature

The FIREBAR element operates at a lower sheath temperature than a round tubular element of equal watt density because of three factors.

1. Flat Surface Geometry

FIREBAR's flat, vertical geometry is streamline. The liquid's flow past the heating element's surface is not impaired by back eddies inherent in the round tubular shape. The FIREBAR's streamline shape results in fluids flowing more freely with more heat carried away from the sheath.

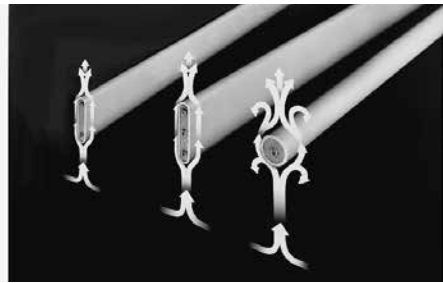

2. Normal to the Flow

The element's width (thickness) of both 1 inch and 5/8 inch FIREBAR elements is just 0.235 in. (5.9 mm). Compared to a 0.430 in. (11 mm) round tubular element, this relative thinness further reduces drag on liquids or gases flowing past the heater.

3. Buoyancy Force

The FIREBAR element's boundary layer, or vertical side, is greater than virtually all round tubular elements. This is 1.010 and 0.650 in. (25.6 and 16.5 mm) for the one inch and 5/8 in. FIREBARs respectively, compared to a 0.430 in. (11 mm) diameter on a round tubular element. The FIREBAR element's increased height, relative to flow, increases the buoyancy force in viscous liquids. This buoyancy force can be as much as 10 times greater depending on the FIREBAR element and liquid used.

Comparative Widths

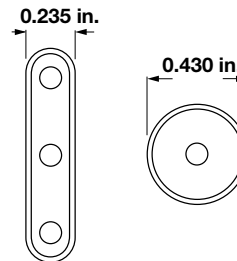

Watt Density and Surface Area Advantages

The surface area per linear inch of a 1 in. FIREBAR is 70 percent greater than the 0.430 in. (11 mm) diameter round tubular element. The 5/8 in. FIREBAR is nearly 10 percent greater.

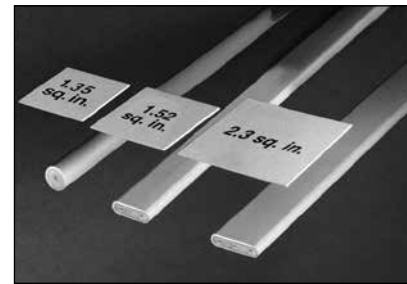

Element Type	Surface Area Per Linear inch (cm)	
	in ²	cm ²
1 in. FIREBAR	2.30 in ²	(5.84 cm ²)
5/8 in. FIREBAR	1.52 in ²	(3.86 cm ²)
0.430 in. Round	1.35 in ²	(3.43 cm ²)

Flat vs. Round Geometry Comparisons

The unique flat surface geometry of the FIREBAR element offers more versatility in solving heater problems than the conventional round tubular element. The following comparisons show how the FIREBAR element consistently outperforms round tubular heaters. FIREBAR elements can:

- Reduce coking and fluid degrading
- Increase heater power within application space parameters
- Provide superior heat transfer in clamp-on applications resulting from greater surface area contact
- Lower watt density

Reducing watt density or sheath temperature extends life. The FIREBAR element allows you to do either, without sacrificing equipment performance ... as is proven by the accompanying *Heater Oil Test, Air Flow and Watt Density vs. Sheath Temperature* graphs.

Tubular Heaters

FIREBAR Single/Double-Ended Heaters

Technical Data

The *FIREBAR Heater Oil Test* graph compares sheath temperatures of 40 W/in² (6.7 W/cm²) flat and round tubular elements. The FIREBAR element consistently operates at a lower sheath temperature than the round tubular element, even when light oils are tested at different temperatures. This reduces the chance that coking and fluid degradation will occur.

In fact, the FIREBAR element's sheath temperature at 40 W/in² (6.7 W/cm²) is lower than a 30 W/in² (4.6 W/cm²) round tubular element.

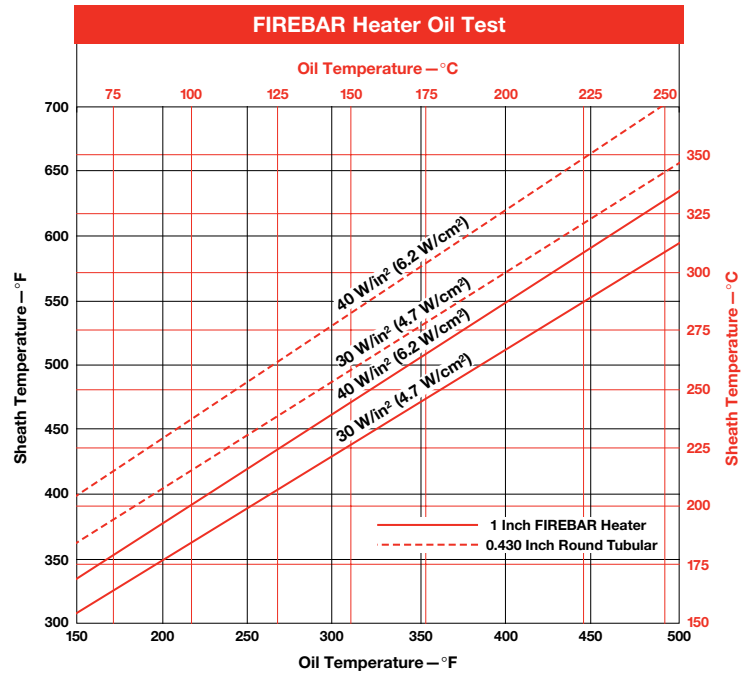

Heater Size and Power

The *Heater Size Comparison* chart shows, at the same wattage and watt density, the FIREBAR element is 38 percent shorter than a 0.430 in. (11 mm) round tubular element. The FIREBAR element requires less space in application and equipment designs.

Heater Size Comparison

Element	Heated Length in. (mm)	Wattage	W/in ²	(W/cm ²)
1 in. FIREBAR Element	19 ⁷ / ₈ (504.8)	1000	23	(3.6)
0.430 in. Round Tubular Element	32 ¹ / ₄ (819.0)	1000	23	(3.6)

The *Heater Power Comparison* chart demonstrates equal watt density, element length and increased total wattage for the FIREBAR element. The power in the FIREBAR element is 70 percent greater.

Heater Power Comparison

Element	Heated Length in. (mm)	Wattage	W/in ²	(W/cm ²)
1 in. FIREBAR Element	32 ¹ / ₄ (819.0)	1700	23	(3.6)
0.430 in. Round Tubular Element	32 ¹ / ₄ (819.0)	1000	23	(3.6)

Tubular Heaters

FIREBAR Single/Double-Ended Heaters

Technical Data (Continued)

Clamp-On Applications

Direct immersion in the liquid may not always be practical. In these instances the FIREBAR element can be clamped to a tank wall. Heat from the FIREBAR is conducted to the tank wall and into the media.

FIREBAR elements are also economical platen heaters. The *Platen Heating* graph shows FIREBAR's large, flat surface area allows it to operate at twice the watt density of round tubular elements ... without sacrificing heater life.

Clamps should be placed approximately 6 in. (150 mm) apart and torqued down with 60 in.-lbs (6.8 Newton meters).

Platen Heating (°F)

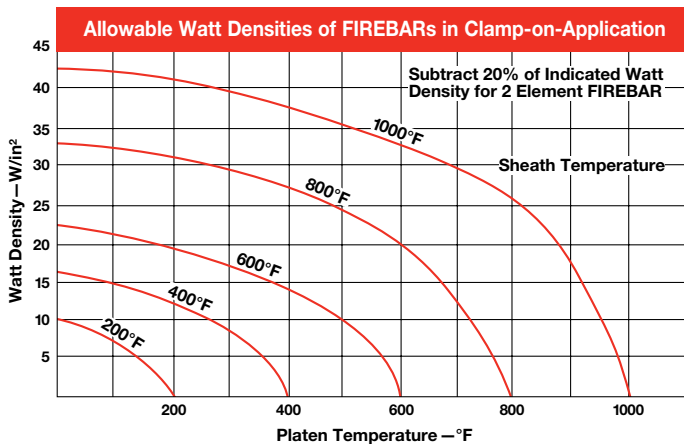

Platen Heating (°C)

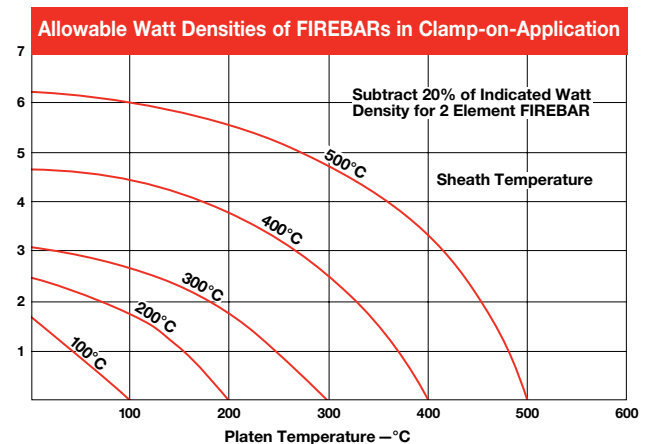

Watt Density vs. Sheath Temperature

The *Watt Density vs. Sheath Temperature* graph features sheath temperature curves for commonly heated substances. A FIREBAR element's watt density will result in the sheath temperature shown at the intersecting point of its vertical watt density line and substance curve.

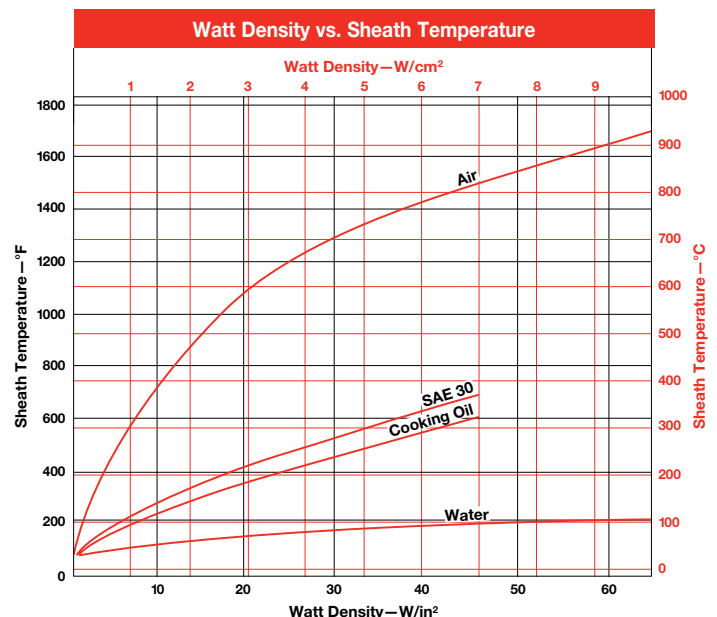

Tubular Heaters

FIREBAR Single/Double-Ended Heaters

Technical Data (Continued)

Air Heating

The Air Flow/Watt Density/Sheath Temperature graph shows the relationship between air flow, watt density and sheath temperature. Keep in mind that lower sheath temperature yields longer heater life.

To use the Air Flow graph, determine the air flow in feet per second (or meters per second). Then follow the curve to find the recommended sheath temperature and watt density.



Air Flow Normal to Sheath Geometry

Air Flow/Watt Density/Sheath Temperature (°F)

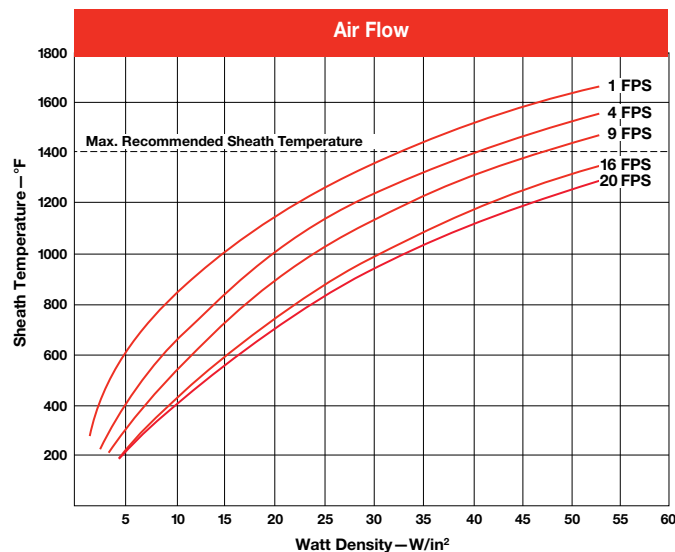

Air Flow/Watt Density/Sheath Temperature (°C)

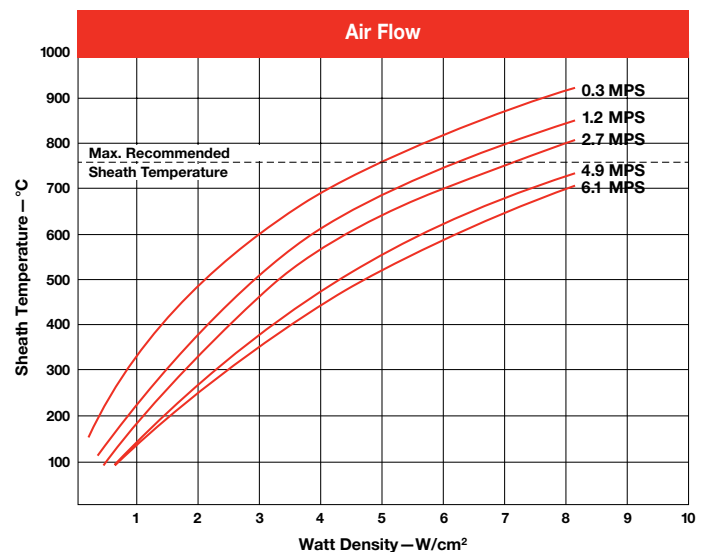

Moisture Resistant Seals

A lavacone seal is provided to prevent moisture and contaminants from entering the heater. Upon request, optional silicone rubber (RTV) and epoxy resin seals may be ordered.

Silicone Rubber (RTV) Seal

Silicone rubber RTV seals are 1/8 in. (3.2 mm) moisture barriers surrounding the terminal pins at the end of the sheath. Silicone rubber is effective to 392°F (200°C).

Epoxy Resin Seal

Epoxy resin seals are 1/8 in. (3.2 mm) moisture barriers surrounding the terminal pins at the end of the sheath. Epoxy resin is effective to 194°F (90°C) or 356°F (180°C), and recommended for water heating applications.

Application Hints

- Choose a FIREBAR heating element instead of an assembly, when the application requires lower wattages or smaller system packages.
- Keep terminations clean, dry and tight.
- Extend the heated section completely into the media being heated at all times to maximize heat transfer and heater life.
- Do not locate the end of the heated length within a bend, unless the radius is 3 in. (76 mm) or larger.
- Ensure termination temperatures do not exceed 392°F (200°C) or the maximum temperature rating of the end seal, whichever is lower.

Tubular Heaters

FIREBAR Single/Double-Ended Heaters

All FIREBAR heaters are available with a variety of termination options. Contact your Watlow representative for availability.

Technical Data (Continued)

Terminations

Part Number*	Termination	Phase	Wiring	1 in. FIREBAR		5/8 in. FIREBAR	
				Dual-Ended	S. End/FINBAR	Dual-Ended	Single-Ended
A1	Sil-A-Blend™ 200°C lead wire	1	Parallel	Yes	Yes	Yes	Yes
A2	Sil-A-Blend™ 200°C lead wire	1	Series	Yes	No	Yes	No
A3	Sil-A-Blend™ 200°C lead wire	3	Delta	Yes	No	No	No
A4	Sil-A-Blend™ 200°C lead wire	3	Wye	Yes	Yes	No	No
B1	TGGT 250°C lead wire	1	Parallel	Yes	Yes	Yes	Yes
B2	TGGT 250°C lead wire	1	Series	Yes	No	Yes	No
B3	TGGT 250°C lead wire	3	Delta	Yes	No	No	No
B4	TGGT 250°C lead wire	3	Wye	Yes	Yes	No	No
C1	1/4 in. quick connect (spade)	1	Parallel	Yes	Yes	Yes	Yes
C2	1/4 in. quick connect (spade)	1	Series	Yes	No	No	No
D1	Screw lug (plate) terminal	1	Parallel	Yes	Yes	Yes	Yes
D2	Screw lug (plate) terminal	1	Series	Yes	No	No	No
D3	Screw lug (plate) terminal	3	Delta	Yes	No	No	No
E1	#10-32 stud terminal	1	Parallel	Yes	Yes	Yes	Yes
E2	#10-32 stud terminal	1	Series	Yes	No	No	No
E3	#10-32 stud terminal	3	Delta	Yes	No	No	No

Termination Code Number Legend*

- A = Silicone rubber insulation (Sil-A-Blend™) with fiberglass oversleeves Rated to 392°F (200°C)
- B = High-temperature TGGT insulation with fiberglass oversleeves Rated to 480°F (250°C)
- C = Nickel-plated steel quick connect

- D = Nickel-plated steel screw lug with ceramic insulator and plated steel screw
- E = #10-32 nickel-plated steel threaded stud with plated steel nuts and washers

Electrical Configuration

- 1 = 1-phase parallel, 2 = 1-phase series, 3 = 3-phase delta, 4 = 3-phase wye

Double-End/Single-End 1 in. FIREBAR^①

Flexible Lead Wire^①

A, B



- Double-End 1 in. FIREBAR
- Single-End 1 in. FIREBAR
- FINBAR

Quick Connect (Spade)

C1

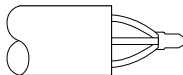

- Double-End 1 in. FIREBAR

Quick Connect (Spade)

C2



- Double-End 1 in. FIREBAR

Screw Lug (Plate)

D1

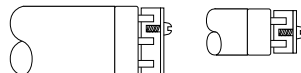

- Double-End 1 & 5/8 in. FIREBAR

Screw Lug (Plate)

D2

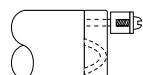

- Double-End 1 in. FIREBAR

Screw Lug (Plate)

D3

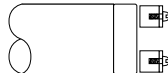

- Double-End 1 in. FIREBAR

3-phase delta wiring example



Threaded Stud

E2

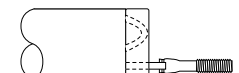

- Double-End 1 in. FIREBAR

Threaded Stud

E3



- Double-End 1 in. FIREBAR

3-phase delta wiring example

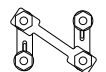

① Flexible lead wires are 12 in. (305 mm) long unless otherwise specified.

Single-End FIREBAR, Double-End FINBAR 1 5/8 in. FIREBAR^①

Flexible Lead Wire^①

A, B



- Single-End 1 in. FIREBAR
- Double-End 5/8 in. FIREBAR
- Single-End 5/8 in. FIREBAR
- FINBAR

Quick Connect (Spade)

C3



- Single-End 1 FIREBAR
- FINBAR
- Double-End 5/8 in. FIREBAR
- Single-End 5/8 in. FIREBAR

Screw Lug (Plate)

D4

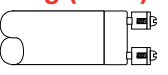

- Single-End 1 in. FIREBAR
- FINBAR

- Double-End 5/8 in. FIREBAR
- Single-End 5/8 in. FIREBAR

Threaded Stud

E4

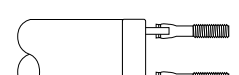

- Single-End 1 in. FIREBAR
- FINBAR

① Flexible lead wires are 12 in. (305 mm) long unless otherwise specified.

Tubular Heaters

FIREBAR Single/Double-Ended Heaters

Bending

Major and Minor Axis Bending Parameters

The following illustrations detail the recommended major and minor axis bend parameters for FIREBAR elements. These illustrations show the relationship between the type of bend and the location of heat and no-heat sections. See the next two pages for the 15 common bend formations.

Note: Watlow does not recommend field bending FIREBAR elements. If the element must be bent in the field, please contact your Watlow representative for assistance.

180° Minor Axis Heated Bend

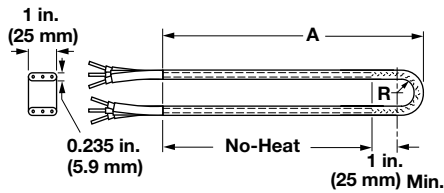

180° Major Axis Heated Bend

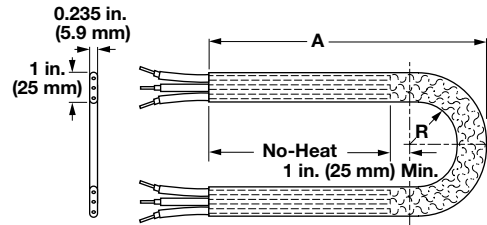

90° Minor Axis Heated Bend

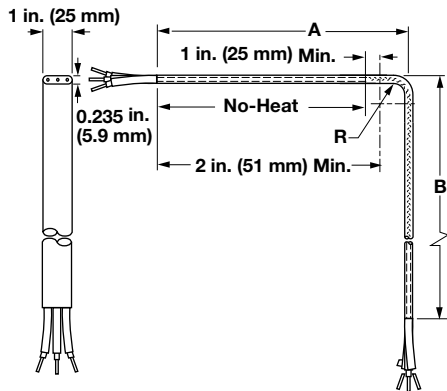

90° Major Axis Heated Bend

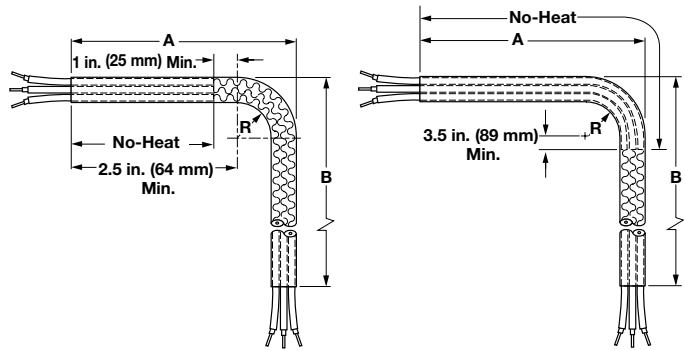

90° Minor Axis Un-Heated Bend

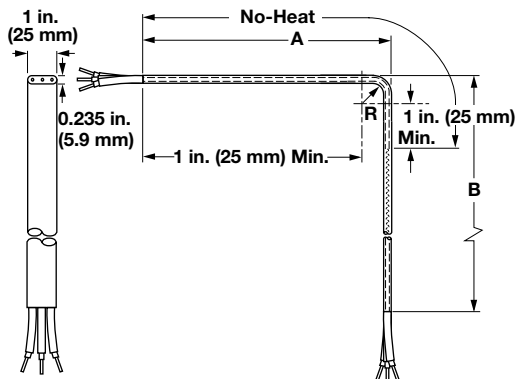

180° Major Axis Bends

FIREBAR Size		Radius		Arc Length
in.	(mm)	in.	(mm)	
5/8	(15.9)	3/4	(19.0)	3.125
5/8	(15.9)	1	(25.0)	3.900
5/8	(15.9)	1 1/4	(32.0)	4.620
5/8	(15.9)	1 1/2	(38.0)	5.600
1	(25.0)	1	(25.0)	4.335
1	(25.0)	1 1/4	(32.0)	5.121
1	(25.0)	1 1/2	(38.0)	5.906

Tubular Heaters

FIREBAR Single/Double-Ended Heaters

Bend Formations

FIREBAR elements can be formed into spirals, compounds, multi-axis and multi-plane configurations from 15 common bends. Custom bending with tighter tolerances can be made to meet specific application needs.

Formation is limited by bending parameters specified in the illustrations of major and minor axis bends on the previous page. On these illustrations, please note the no-heat end location.

The no-heat end junction must be located a minimum of 1 in. (25 mm) from any bend. If these parameters are not followed, the heater may fail prematurely.

Illustrated below are the common bends that can be ordered for all FIREBAR heating elements.

To order a common bend, specify the **figure number** and **critical dimensions**.

Note: The alpha characters and symbols are used to designate specific dimensions within each illustration.

Minor Axis	Major Axis	Minor Axis	Major Axis
Figure 1A 	Figure 1B 	Figure 2A 	Figure 2B
Figure 3A 	Figure 3B 	Figure 4A 	Figure 4B
Figure 5A 	Figure 5B 	Figure 6A 	Figure 6B
Figure 7A 	Figure 7B 	Figure 8A 	Figure 8B

Tubular Heaters

FIREBAR Single/Double-Ended Heaters

Bend Formation (Continued)

Minor Axis	Major Axis	Minor Axis	Major Axis
<p>Figure 9A</p>	<p>Figure 9B</p>	<p>Figure 10A</p>	<p>Bend Figure 10B Not Available On Major Axis</p>
<p>Figure 11A</p>	<p>Bend Figure 11B Not Available On Major Axis</p>	<p>Figure 12A</p>	<p>Figure 12B</p>
<p>Figure 13A</p>	<p>Figure 13B</p>	<p>Figure 14A</p>	<p>Figure 14B</p>
<p>Figure 15A</p>	<p>Figure 15B</p>		

Tubular Heaters

FIREBAR Single/Double-Ended Heaters

Mounting Brackets

Steel brackets provide element mounting in non-pressurized applications. In air heating applications, an 18-gauge aluminized steel bracket is press fitted to the element. A 1/4 in. (6 mm) thick steel bracket is brazed or welded liquid-tight to the element for liquid heating. Upon request, stainless steel brackets can be provided. Special sizes also available.

The bracket is located 1/2 in. (13 mm) from the sheath's end, 1/16 in. (1.6 mm) if welded. Available on 5/8 in. (15.9 mm) FIREBAR as **made-to-order** only.

To order, specify **mounting bracket** as well as type, location, material and size.

Type 1

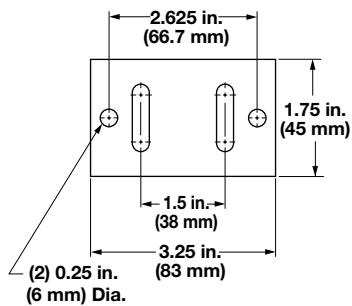

Type 2

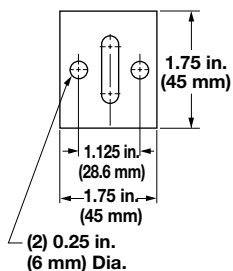

Type 3

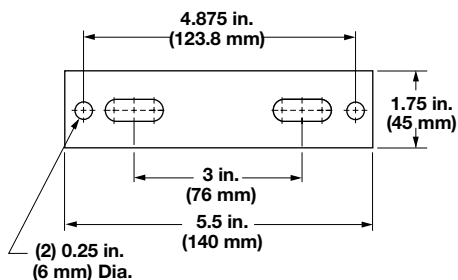

Water-Tight Double-Leg Threaded Fitting

A threaded 1 5/8 in.-10 UNC stainless steel fitting with flange on the heater sheath provides rigid, leak-proof mounting through tank walls. This fitting allows both legs of the heater to pass through the same opening. A gasket, plated steel washer and hex nut are included. The threaded end of the bulkhead is mounted flush with the sheath's end, unless otherwise specified. Available on **1 inch FIREBAR only (brazed only, available)**.

To order, specify **water-tight double-leg threaded fitting**.

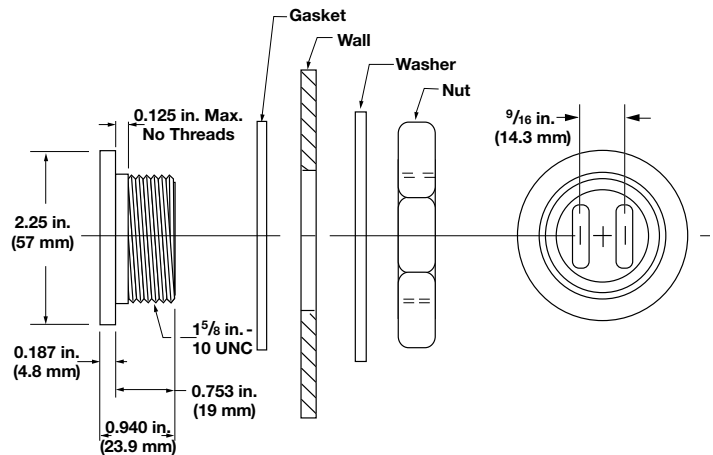

Surface Finish

Bright Annealing

Bright annealing is a process that produces a smooth, metallic finish. It is a special annealed finish created in a non-oxidizing atmosphere. This finish is popular in the pharmaceutical and foodservice/beverage markets.

To order, specify **bright annealing**.

Passivation

During manufacturing, particles of iron or tool steel may be embedded in the stainless steel or alloy sheath. If not removed, these particles may corrode and produce rust spots. For critical sheath applications, passivation will remove free iron from the sheath.

To order, specify **passivation**.

Extended Capabilities For FIREBAR Single/Double-Ended Heaters

Internal Thermocouples

To provide protection against element over-temperature conditions, 1 in. (25 mm) double-ended FIREBAR elements can be ordered with ASTM **Type K** thermocouples. This is accomplished by eliminating the center resistance coil and embedding the thermocouple junction inside the sheath. Thus, thermocouples are available only on two resistance coil, 1 in. (25 mm) FIREBAR elements.

To order, specify:

- **Type K** thermocouple
- Distance the junction is to be located from the element's end
- Lead length

Thermocouple Types

ASTM Type	Conductor Positive	Characteristics		Recommended Temp. Range °F (°C)
		Negative		
K	Chromel® (Non-magnetic)	Alumel® (Magnetic)		0 to 2000 (-20 to 1100)

① **Type K** thermocouples are rated 32 to 2282°F (0 to 1250°C). Watlow does not recommend exceeding the temperature range shown on this chart.

Options for 5/8-Inch FIREBAR

- Electropolished finish
- Custom formations
- Cordset
- Termination overmolds (silicone or neoprene)
- Terminal enclosures (general purpose, moisture resistant, moisture/explosion resistant and explosion resistant)
- Internal thermocouple (dual end only, single or dual coil)
- Custom wattage tolerance (±5%)

Options for One-Inch FIREBAR

- Electropolished finish
- Bulkhead, single leg
- Custom formations
- Cordset
- Termination overmolds (silicone or neoprene)
- Terminal enclosures (general purpose, moisture resistant, moisture/explosion resistant and explosion resistant)
- Internal thermocouple (dual end only, single or dual coil)
- Custom wattage tolerance (±5%)

Mounting Brackets

Threaded Bulkheads

A threaded stainless steel bushing with flange on the heater sheath provides rigid, leak-proof mounting through tank walls. A gasket, plated steel washer and hex nut are included (brazed only, available).

To order, specify **threaded bulkheads**.

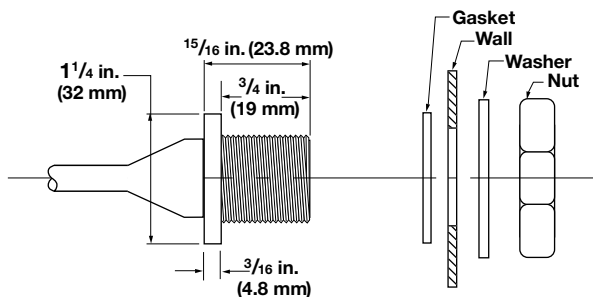

Illustration for 1-inch FIREBAR

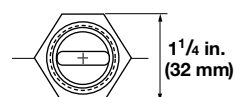

Illustration for 5/8-inch FIREBAR

Heater Size in.	(mm)	Thread Size
5/8	(15.9)	7/8-14 UNF-2A
1	(25.0)	3/4-16 UNF-2A

Tubular Heaters

FIREBAR Single/Double-Ended Heaters

One-Inch, Double-Ended FIREBAR

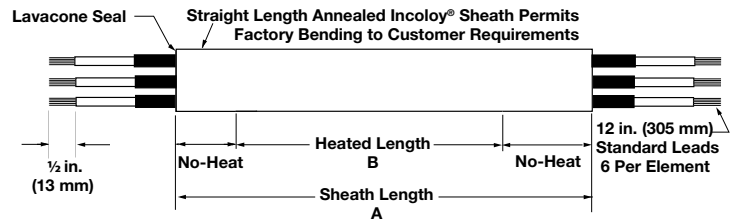

FIREBAR Description	Sheath A Dimension		Heated B Dimension		Watts	Part Number			Est. Net Wt.	
	in.	(mm)	in.	(mm)		120VAC	240VAC	480VAC	lbs	(kg)

Applications: Asphalt, Paraffin (Solid), Bunker Oil, Clamp-On

6 W/in ² Alloy 800 (1 W/cm ²)	35	(889)	25	(635)	310	FBN351WD			1.3	(0.6)
	41	(1041)	31	(787)	410	FBN411WD			1.5	(0.7)
	51	(1295)	41	(1041)	530	FBN511WD	FBN5110WD		1.9	(0.9)
	62	(1574)	52	(1320)	650	FBN621WD	FBN6210WD		2.3	(1.1)
	72	(1828)	62	(1574)	800	FBN721WD	FBN7210WD		2.6	(1.2)
	93	(2362)	83	(2108)	1,060	FBN931WD	FBN9310WD		3.4	(1.6)
	114	(2895)	104	(2641)	1,350	FBN1141WD	FBN11410WD		4.2	(1.9)

Applications: Griddles, Fuel Oil, Clamp-On

10 W/in ² Alloy 800 (1.6 W/cm ²)	25	(635)	22	(558)	500	FBN251WL			0.9	(0.4)
	35	(889)	32	(812)	750	FBN351WL	FBN3510WL		1.3	(0.6)
	47	(1193)	43	(1092)	1,000	FBN471WL	FBN4710WL		1.7	(0.8)
	69	(1752)	65	(1651)	1,500	FBN691WL	FBN6910WL		2.5	(1.2)
	90	(2286)	86	(2184)	2,000	FBN901WL	FBN9010WL		3.3	(1.5)

Applications: Clamp-On, Medium Weight Oils, Liquid Paraffin, Low-Temperature Ovens 400°F (205°C)

15 W/in ² ① Alloy 800 (2.3 W/cm ²)	29	(736)	19	(482)	670		FBN2910WE		1.1	(0.5)
	34	(863)	24	(609)	830		FBN3410WE		1.3	(0.6)
	39	(990)	29	(736)	1,000		FBN3910WE		1.4	(0.7)
	48	(1219)	38	(965)	1,330		FBN4810WE	FBN4811WE	1.8	(0.9)
	58	(1473)	48	(1219)	1,670		FBN5810WE	FBN5811WE	2.1	(1.0)
	68	(1727)	58	(1473)	2,000		FBN6810WE	FBN6811WE	2.5	(1.2)
	87	(2209)	77	(1955)	2,670		FBN8710WE	FBN8711WE	3.2	(1.5)
	106	(2692)	96	(2438)	3,330		FBN10610WE	FBN10611WE	3.9	(1.8)

Applications: Radiant, Platens, Dies, Low-Temperature Ovens 300°F (150°C)

20 W/in ² Alloy 800 (3.1 W/cm ²)	15	(381)	11	(279)	500	FBN151WM			0.6	(0.3)
	20	(508)	16	(406)	750	FBN201WM			0.8	(0.4)
	26	(660)	22	(558)	1,000	FBN261WM	FBN2610WM		1.0	(0.5)
	36	(914)	32	(812)	1,500	FBN361WM	FBN3610WM		1.3	(0.6)
	48	(1219)	43	(1092)	2,000	FBN481WM	FBN4810WM		1.8	(0.9)
	70	(1778)	65	(1651)	3,000		FBN7010WM	FBN7011WM	2.6	(1.2)
	91	(2311)	85	(2159)	4,000		FBN9110WM	FBN9111WM	3.3	(1.5)

Applications: Degreasing Solutions, Heat Transfer Oils

23 W/in ² Alloy 800 (3.6 W/cm ²)	35	(889)	25	(635)	1,250	FBN351WT	FBN3510WT		1.3	(0.6)
	41	(1041)	31	(787)	1,625	FBN411WT	FBN4110WT		1.5	(0.7)
	51	(1295)	41	(1041)	2,125	FBN511WT	FBN5110WT	FBN5111WT	1.9	(0.9)
	62	(1574)	52	(1320)	2,625	FBN621WT	FBN6210WT	FBN6211WT	2.3	(1.1)
	72	(1828)	62	(1574)	3,200	FBN721WT	FBN7210WT	FBN7211WT	2.6	(1.2)
	93	(2362)	83	(2108)	4,250	FBN931WT	FBN9310WT	FBN9311WT	3.4	(1.6)
	114	(2895)	104	(2641)	5,400	FBN1141WT	FBN11410WT	FBN11411WT	4.2	(1.9)

CONTINUED

• Manufacturing lead times

Truck Shipment only

Tubular Heaters

FIREBAR Single/Double-Ended Heaters

One-Inch, Double-Ended FIREBAR (Continued)

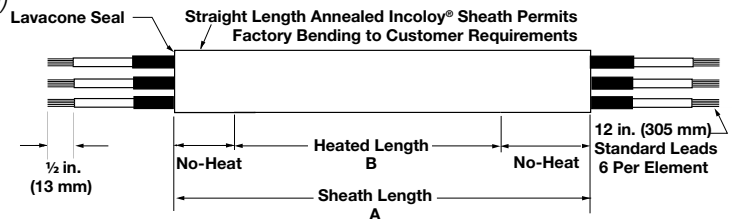

FIREBAR Description	Sheath A Dimension		Heated B Dimension		Watts	Part Number			Est. Net Wt.	
	in.	(mm)	in.	(mm)		120VAC	240VAC	480VAC	lbs	(kg)

Applications: Cooking Oils, Mild Caustic Solution, Ethylene Glycol (100%)

30 W/in² Alloy 800 (4.7 W/cm²)	16	(406)	10	(254)	750	FBN161WH			0.6	(0.3)
	20	(508)	14	(355)	1000	FBN201WH			0.8	(0.4)
	27	(685)	21	(533)	1500	FBN271WH	FBN2710WH		1.0	(0.5)
	34	(863)	28	(711)	2000	FBN341WH	FBN3410WH		1.3	(0.6)
	50	(1270)	43	(1092)	3000		FBN5010WH	FBN5011WH	1.8	(0.9)
	64	(1625)	57	(1447)	4000		FBN6410WH	FBN6411WH	2.4	(1.1)
80	(2032)	72	(1828)	5000		FBN8010WH	FBN8011WH	2.9	(1.4)	

Applications: Process Water, Ethylene Glycol (50%)

40 W/in² Alloy 800 (6.2 W/cm²)	25	(635)	22	(558)	2000		FBN2510WK		0.9	(0.4)
	35	(889)	32	(812)	3000		FBN3510WK	FBN3511WK	1.3	(0.6)
	47	(1193)	43	(1092)	4000		FBN4710WK	FBN4711WK	1.7	(0.8)
	69	(1752)	65	(1651)	6000		FBN6910WK	FBN6911WK	2.5	(1.2)
	90	(2286)	86	(2184)	8000		FBN9010WK	FBN9011WK	3.3	(1.5)
45 W/in² Alloy 800 (7 W/cm²)	29	(736)	19	(482)	2000		FBN2910WP		1.1	(0.5)
	34	(863)	24	(609)	2500		FBN3410WP		1.3	(0.6)
	39	(990)	29	(736)	3000		FBN3910WP		1.4	(0.7)
	48	(1219)	38	(965)	4000		FBN4810WP	FBN4811WP	1.8	(0.9)
	58	(1473)	48	(1219)	5000		FBN5810WP	FBN5811WP	2.1	(1.0)
	68	(1727)	58	(1473)	6000		FBN6810WP	FBN6811WP	2.5	(1.2)
87	(2209)	77	(1955)	8000		FBN8710WP	FBN8711WP	3.2	(1.5)	
106	(2692)	96	(2438)	10,000		FBN10610WP	FBN10611WP	3.9	(1.8)	

Applications: Clean and Potable Water

80 W/in² Alloy 800 (12.4 W/cm²)	15	(381)	11	(279)	2000		FBN1510WJ		0.6	(0.3)
	20	(508)	16	(406)	3000		FBN2010WJ		0.8	(0.4)
	26	(660)	22	(558)	4000		FBN2610WJ	FBN2611WJ	1.0	(0.5)
	36	(914)	32	(812)	6000		FBN3610WJ	FBN3611WJ	1.3	(0.6)
	48	(1219)	43	(1092)	8000		FBN4810WJ	FBN4811WJ	1.8	(0.9)
90 W/in² Alloy 800 (14 W/cm²)	70	(1778)	65	(1651)	12,000			FBN7011WJ	2.6	(1.2)
	91	(2311)	85	(2159)	16,000			FBN9111WJ	3.3	(1.5)
	35	(889)	25	(635)	5000	FBN351WG	FBN3510WG	FBN3511WG	1.3	(0.6)
	41	(1041)	31	(787)	6500	FBN411WG	FBN4110WG	FBN4111WG	1.5	(0.7)
	51	(1295)	41	(1041)	8500		FBN5110WG	FBN5111WG	1.9	(0.9)
	62	(1574)	52	(1320)	10,500		FBN6210WG	FBN6211WG	2.3	(1.1)
	72	(1828)	62	(1574)	12,750		FBN7210WG	FBN7211WG	2.6	(1.2)
93	(2362)	83	(2108)	17,000			FBN931WG	3.4	(1.6)	
114	(2895)	104	(2641)	21,500			FBN11411WG	3.4	(1.6)	

• Manufacturing lead times

Truck Shipment only

Tubular Heaters

FIREBAR Single/Double-Ended Heaters

5/8-Inch Double-Ended FIREBAR

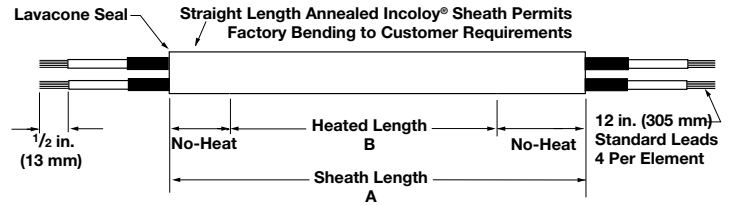

FIREBAR Description	Sheath A Dimension		Heated B Dimension		Watts	Part Number			Est. Net Wt.	
	in.	(mm)	in.	(mm)		120VAC	240VAC	480VAC	lbs	(kg)

Applications: Degreasing Fluids, Heat Transfer Oils

23 W/in² ① Alloy 800 (3.6 W/cm²)	19	(483)	11	(279)	375	FAN191WT			0.5	(0.3)
	22	(559)	14	(356)	500	FAN221WT	FAN2210WT		0.5	(0.3)
	26	(660)	18	(457)	625	FAN261WT	FAN2610WT		0.6	(0.3)
	30	(762)	22	(559)	750	FAN301WT	FAN3010WT		0.7	(0.4)
	37	(940)	29	(737)	1000	FAN371WT	FAN3710WT		0.9	(0.5)
	44	(1118)	36	(914)	1250	FAN441WT	FAN4410WT		1.0	(0.5)
	51	(1295)	43	(1092)	1500	FAN511WT	FAN5110WT		1.2	(0.6)

Applications: Clean and Potable Water

90 W/in² Alloy 800 (14 W/cm²)	15	(381)	7	(178)	1000	FAN151WG	FAN1510WG		0.4	(0.2)
	19	(483)	11	(279)	1500	FAN191WG	FAN1910WG	FAN1911WG	0.5	(0.3)
	22	(559)	14	(356)	2000	FAN221WG	FAN2210WG	FAN2211WG	0.5	(0.3)
	26	(660)	18	(457)	2500	FAN261WG	FAN2610WG	FAN2611WG	0.6	(0.3)
	30	(762)	22	(559)	3000	FAN301WG	FAN3010WG	FAN3011WG	0.7	(0.4)
	37	(940)	29	(737)	4000		FAN3710WG	FAN3711WG	0.9	(0.5)
	44	(1118)	36	(914)	5000		FAN4410WG	FAN4411WG	1.0	(0.5)
	51	(1295)	43	(1092)	6000		FAN5110WG	FAN5111WG	1.2	(0.6)

- Manufacturing lead times

Tubular Heaters

FIREBAR Single/Double-Ended Heaters

One-Inch, Single-Ended FIREBAR

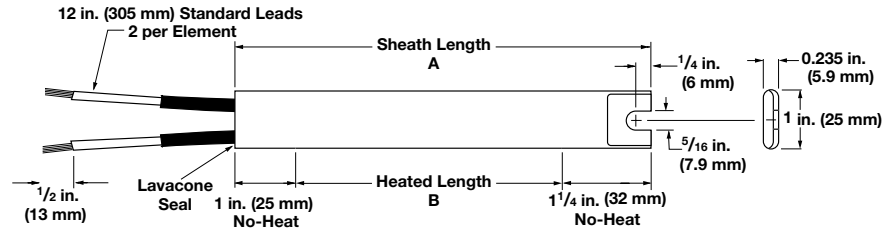

FIREBAR Description	Sheath A Dimension		Heated B Dimension		Watts	Part Number		Est. Net Wt.	
	in.	(mm)	in.	(mm)		120VAC	240VAC	lbs	(kg)

Applications: Radiant, Platens, Dies, Low-Temperature Ovens 300°F (150°C)

20 W/in ² 304 SS (3.1 W/cm ²)	8 ³ / ₄ (222.0)	6 ¹ / ₂ (165.0)	300	FSP91WM		0.4 (0.2)
	10 ¹ / ₄ (260.0)	7 ¹ / ₂ (203.0)	375	FSP101WM		0.4 (0.2)
	12 ¹ / ₄ (311.0)	10 (254.0)	450	FSP121WM		0.5 (0.3)
	13 ¹ / ₂ (343.0)	11 ¹ / ₄ (286.0)	500	FSP141WM		0.5 (0.3)
	16 ¹ / ₈ (408.6)	13 ⁷ / ₈ (352.4)	650	FSP161WM	FSP1610WM	0.6 (0.3)
	17 ³ / ₄ (451.0)	15 ¹ / ₂ (393.0)	725	FSP181WM	FSP1810WM	0.7 (0.4)
	19 ¹ / ₄ (489.0)	17 (431.0)	800	FSP191WM	FSP1910WM	0.7 (0.4)
	22 (558.0)	19 ³ / ₄ (502.0)	900	FSP221WM	FSP2210WM	0.8 (0.4)
	23 ³ / ₄ (603.0)	21 ¹ / ₂ (546.0)	1,000	FSP241WM	FSP2410WM	0.9 (0.4)
	25 (635.0)	22 ³ / ₄ (578.0)	1,050	FSP251WM	FSP2510WM	0.9 (0.4)
	28 ⁵ / ₈ (727.1)	26 ³ / ₈ (670.0)	1,250	FSP291WM	FSP2910WM	1.1 (0.5)
	31 ⁵ / ₈ (803.3)	29 ³ / ₈ (746.1)	1,350	FSP321WM	FSP3210WM	1.2 (0.6)
	34 ¹ / ₈ (866.8)	31 ⁷ / ₈ (809.6)	1,500		FSP3410WM	1.3 (0.6)
	36 ⁷ / ₈ (936.6)	34 ⁵ / ₈ (879.5)	1,600		FSP3710WM	1.4 (0.7)
	40 ⁵ / ₈ (1031.9)	38 ³ / ₈ (974.7)	1,800		FSP4110WM	1.5 (0.7)
	46 ¹ / ₄ (1175.0)	44 (1117.0)	2,000		FSP4610WM	1.7 (0.8)

Applications: Air Heating

40 W/in ² 304 SS (6.2 W/cm ²)	8 ³ / ₄ (222.0)	6 ¹ / ₂ (165.0)	600	FSP91WK		0.4 (0.2)
	10 ¹ / ₄ (260.0)	7 ¹ / ₂ (203.0)	750	FSP101WK		0.4 (0.2)
	12 ¹ / ₄ (311.0)	10 (254.0)	900	FSP121WK	FSP1210WK	0.5 (0.3)
	13 ¹ / ₂ (343.0)	11 ¹ / ₄ (286.0)	1,000	FSP131WK	FSP1310WK	0.5 (0.3)
	16 ¹ / ₄ (413.0)	13 ⁷ / ₈ (352.4)	1,300	FSP161WK	FSP1610WK	0.6 (0.3)
	17 ³ / ₄ (451.0)	15 ¹ / ₂ (393.0)	1,450	FSP181WK	FSP1810WK	0.7 (0.4)
	19 ¹ / ₄ (489.0)	17 (431.0)	1,600		FSP1910WK	0.7 (0.4)
	22 (558.0)	19 ³ / ₄ (502.0)	1,800		FSP2210WK	0.8 (0.4)
	23 ³ / ₄ (603.0)	21 ¹ / ₂ (546.0)	2,000		FSP2410WK	0.9 (0.4)
	25 (635.0)	22 ³ / ₄ (578.0)	2,100		FSP2510WK	0.9 (0.4)
	28 ⁵ / ₈ (727.1)	26 ³ / ₈ (669.9)	2,500		FSP2910WK	1.1 (0.5)
	31 ⁵ / ₈ (803.2)	29 ³ / ₈ (746.1)	2,700		FSP3210WK	1.2 (0.6)
	34 ¹ / ₈ (866.8)	31 ⁷ / ₈ (809.6)	3,000		FSP3410WK	1.3 (0.6)
	36 ⁷ / ₈ (936.6)	34 ⁵ / ₈ (879.5)	3,200		FSP3710WK	1.4 (0.7)
	40 ⁵ / ₈ (1031.9)	38 ³ / ₈ (974.7)	3,600		FSP4110WK	1.5 (0.7)
	46 ¹ / ₄ (1175.0)	44 (1117.0)	4,000		FSP4610WK	1.7 (0.8)

- Manufacturing lead times

Tubular Heaters

FIREBAR Single/Double-Ended Heaters

5/8-Inch Single-Ended FIREBAR

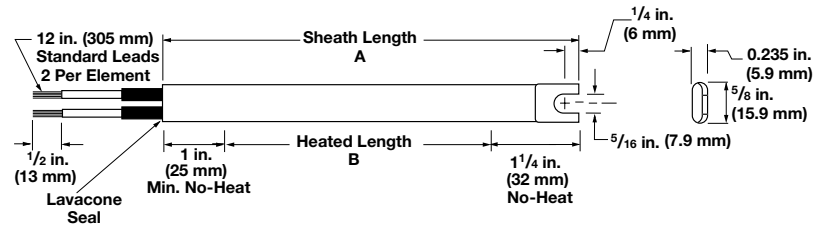

FIREBAR Description	Sheath A Dimension		Heated B Dimension		Watts	Part Number		Est. Net Weight	
	in.	(mm)	in.	(mm)		120VAC	240VAC	lbs	(kg)

Applications: Radiant, Platens, Dies, Low-Temperature Ovens 300°F (150°C)

20 W/in ²	11 1/2	(292)	8	(203)	250	FSA121WM		0.3	(0.2)
Alloy 800	15 1/2	(394)	12	(304)	375	FSA161WM	FSA1610WM	0.4	(0.2)
(3.1 W/cm ²)	19 1/2	(495)	16	(406)	500	FSA201WM	FSA2010WM	0.5	(0.3)
	28	(711)	24	(609)	750	FSA281WM	FSA2810WM	0.6	(0.3)
	36	(914)	32	(812)	1,000	FSA361WM	FSA3610WM	0.8	(0.4)
	52	(1321)	48	(1219)	1,500	FSA521WM	FSA5210WM	1.2	(0.6)

- Manufacturing lead times

Tubular Heaters

FINBAR™ Single-Ended Heaters

Composed of aluminized steel fins press fitted to a one-inch single-ended FIREBAR element. The FINBAR™ is designed to improve heat transfer to the air and permits putting more power in tighter spaces—like forced air ducts, dryers, ovens and load bank resistors.

Heat transfer, lower sheath temperature and element life are all maximized by its finned construction. Installation is simplified by terminations exiting at one end and mounting accommodations on both ends.

Performance Capabilities

- Watt densities up to 50 W/in² (7.7 W/cm²)
- 304 stainless steel sheath temperatures up to 1200°F (650°C)
- Voltages up to 480VAC
- Amperages up to 48 amperes per heater or 16 amperes per coil

Features and Benefits

Rugged aluminized steel fins

- Provides an increase in surface area to approximately 16 square inches for every linear inch of element length. Fins press fitted to the heating element improve heat transfer to the air

Single-ended termination

- Simplifies wiring and installation

Stainless steel mounting bracket, welded to the terminal end, supplied with a slotted end

- Allows ease of installation

Lavacone seals

- Provides protection against humid storage conditions, moisture retardant to 221°F (105°C)

Typical Applications

- Forced air heating for dryers, ovens, ducts
- Still air heating for ovens, comfort heating
- Incubators
- Ink drying
- Load bank resistors

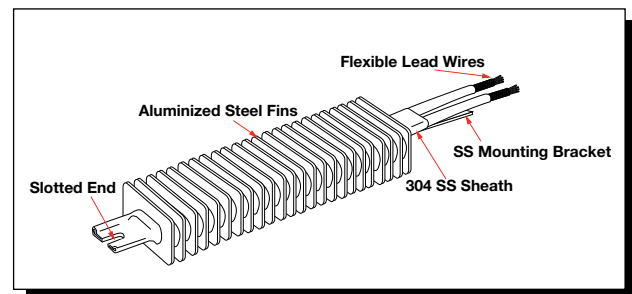
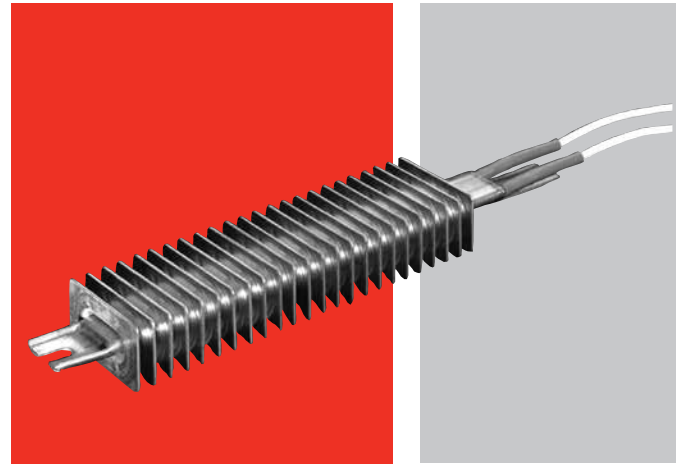

Construction Features

Watt Density: Up to 40 W/in² (6.2 W/cm²)

Fin Surface Area: 16 in²/linear in. (40.5 cm²/linear cm)

Fin Cross Section: 2 x 1 in. (50 x 25 mm)

Maximum Operating Temperature: Sheath material: 304 SS, 1200°F (650°C), Fin material; aluminized steel; 1100°F (600°C)

Heater Length: 11 to 120 in. (280 to 3050 mm)

No-Heat Length: 1 in. (25 mm) min., 12 in. (305 mm) max.

Voltages: Up to 240VAC

Phase: 1-phase parallel or 3-phase wye

Resistance Coils: 1 or 3

Terminations: Flexible lead wires, quick connect (spade), screw lug (plate) and threaded stud

Seal Material: Lavacone, rated to 221°F (105°C)

Single-End Configuration: Slotted

Agency Recognition: Refer to FIREBAR UL®

Tubular Heaters

FINBAR Single-Ended Heaters

Air Heating

The *Watt Density, Air Flow and Sheath Temperature* graph shows the relationship between watt density, air flow velocity and sheath temperature, along with a recommended temperature to avoid deteriorating the fins. Be aware that **lower sheath temperature yields longer heater life**.

The graphic representation is based on a single-ended FINBAR, various air velocities (at 68°F/20°C inlet temperature) and different watt densities.

Watt Density, Air Flow and Sheath Temperature (°F)

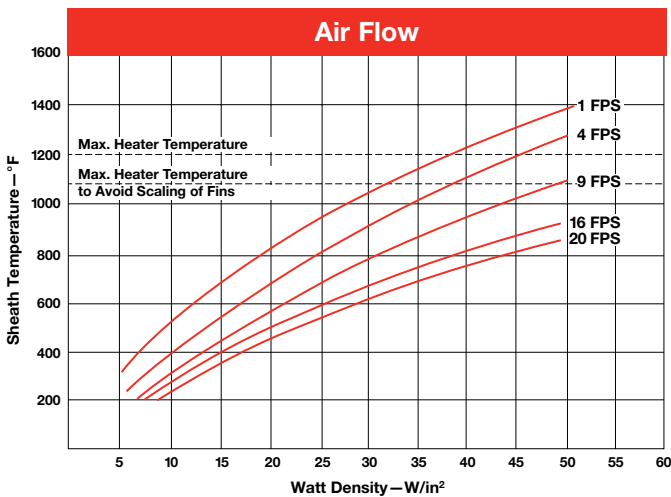

To determine, from the graph, the operating temperature of the FINBAR's sheath, identify the air velocity curve that approximates your application in feet per second (meters per second). Then, look at the vertical line that most closely approximates the FINBAR's watt density. From the intersecting point, read over to the temperature column to determine the sheath's operating temperature.

Watt Density, Air Flow and Sheath Temperature (°C)

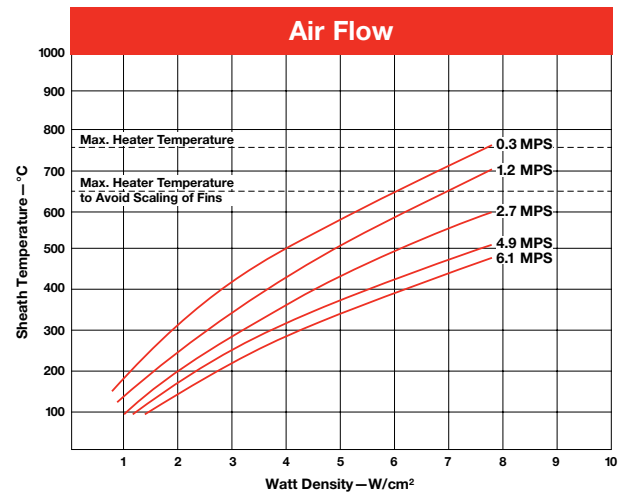

Dual Ended FINBAR

FINBAR elements are typically terminated at one end. Upon request, however, dual-ended FINBAR heaters can be ordered. To order, specify **dual-ended FINBAR** and lead length.

Application Hints

- Avoid deteriorating the fins by not exceeding the recommended maximum fin temperature of 1100°F (600°C).
- Ensure proper air flow to prevent premature heater failure.
- Locate the temperature sensor downstream from heater(s) for process temperature sensing.

The following mounting parameters are recommended:

- Air flow over element must be parallel with the flat side.
- Element center line to element center line spacing must be a minimum of 1½ in. (38 mm).

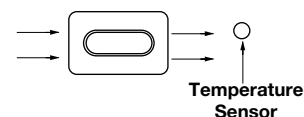

Proper air flow relative to the heater's sheath is parallel with the longer cross sectional axis.

Tubular Heaters

FINBAR Single-Ended Heaters

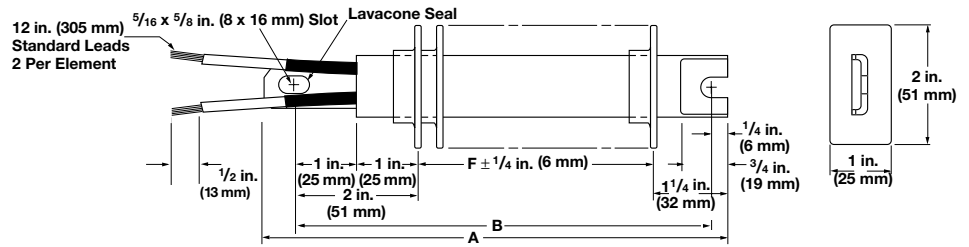

FINBAR Description	Overall A Dimension		Overall F Dimension		Mounting B Dimension		Watts	Part Number		Est. Net Wt.	
	in.	(mm)	in.	(mm)	in.	(mm)		120VAC	240VAC	lbs	(kg)

Application: Forced Air

20 W/in ² 304 SS (3.1 W/cm ²)	10 ¹ / ₄	(260.0)	6 ¹ / ₂	(158.0)	9 ¹ / ₂	(241.0)	300	FSP91WMF		1.4	(0.7)
	11 ³ / ₄	(298.0)	8	(203.0)	11	(279.0)	375	FSP101WMF		1.4	(0.7)
	13 ³ / ₄	(349.0)	10	(254.0)	13	(330.0)	450	FSP121WMF		1.5	(0.7)
	15	(381.0)	11 ¹ / ₄	(285.0)	14 ¹ / ₄	(362.0)	500	FSP141WMF		1.5	(0.7)
	17 ⁵ / ₈	(447.7)	13 ⁷ / ₈	(352.4)	16 ⁷ / ₈	(428.6)	650	FSP161WMF	FSP1610WMF	1.6	(0.8)
	19 ¹ / ₄	(489.0)	15 ¹ / ₂	(393.0)	18 ¹ / ₂	(469.0)	725	FSP181WMF	FSP1810WMF	1.7	(0.8)
	20 ³ / ₄	(527.0)	17	(431.0)	20	(508.0)	800	FSP191WMF	FSP1910WMF	1.7	(0.8)
	23 ¹ / ₂	(597.0)	19 ³ / ₄	(501.0)	22 ³ / ₄	(577.0)	900	FSP221WMF	FSP2210WMF	1.8	(0.9)
	25 ¹ / ₄	(641.0)	21 ¹ / ₂	(546.0)	24 ¹ / ₂	(622.0)	1000	FSP241WMF	FSP2410WMF	1.9	(0.9)
	26 ¹ / ₂	(673.0)	22 ³ / ₄	(577.0)	25 ³ / ₄	(654.0)	1050	FSP251WMF	FSP2510WMF	1.9	(0.9)
	30 ¹ / ₈	(765.2)	26 ³ / ₈	(669.9)	29 ³ / ₈	(746.1)	1250	FSP291WMF	FSP2910WMF	2.1	(1.0)
	33 ¹ / ₈	(841.4)	29 ³ / ₈	(746.1)	32 ³ / ₈	(822.3)	1350	FSP321WMF	FSP3210WMF	2.2	(1.0)
	35 ⁵ / ₈	(904.9)	31 ⁷ / ₈	(809.6)	34 ⁷ / ₈	(885.8)	1500		FSP3410WMF	2.3	(1.1)
	38 ³ / ₈	(974.7)	34 ⁵ / ₈	(879.5)	37 ⁵ / ₈	(955.7)	1600		FSP3710WMF	2.4	(1.1)
42 ¹ / ₈	(1070.0)	38 ³ / ₈	(974.7)	41 ³ / ₈	(1051.0)	1800		FSP4110WMF	2.5	(1.2)	
47 ³ / ₄	(1213.0)	44	(1117.0)	47	(1193.0)	2000		FSP4610WMF	2.7	(1.3)	
40 W/in ² 304 SS (6.2 W/cm ²)	10 ¹ / ₄	(260.0)	6 ¹ / ₂	(158.0)	9 ¹ / ₂	(241.0)	600	FSP91WKF		1.4	(0.7)
	11 ³ / ₄	(298.0)	8	(203.0)	11	(279.0)	750	FSP101WKF		1.4	(0.7)
	13 ³ / ₄	(349.0)	10	(254.0)	13	(330.0)	900	FSP121WKF	FSP1210WKF	1.5	(0.7)
	15	(381.0)	11 ¹ / ₄	(285.0)	14 ¹ / ₄	(362.0)	1000	FSP131WKF	FSP1310WKF	1.5	(0.7)
	17 ⁵ / ₈	(447.7)	13 ⁷ / ₈	(352.4)	16 ⁷ / ₈	(428.6)	1300	FSP161WKF	FSP1610WKF	1.6	(0.8)
	19 ¹ / ₄	(489.0)	15 ¹ / ₂	(393.0)	18 ¹ / ₂	(469.0)	1450	FSP181WKF	FSP1810WKF	1.7	(0.8)
	20 ³ / ₄	(527.0)	17	(431.0)	20	(508.0)	1600		FSP1910WKF	1.7	(0.8)
	23 ¹ / ₂	(597.0)	19 ³ / ₄	(501.0)	22 ³ / ₄	(577.0)	1800		FSP2210WKF	1.8	(0.9)
	25 ¹ / ₄	(641.0)	21 ¹ / ₂	(546.0)	24 ¹ / ₂	(622.0)	2000		FSP2410WKF	1.9	(0.9)
	26 ¹ / ₂	(673.0)	22 ³ / ₄	(577.0)	25 ³ / ₄	(654.0)	2100		FSP2510WKF	1.9	(0.9)
	30 ¹ / ₈	(765.2)	26 ³ / ₈	(669.9)	29 ³ / ₈	(746.1)	2500		FSP2910WKF	2.1	(1.0)
	33 ¹ / ₈	(841.4)	29 ³ / ₈	(746.1)	32 ³ / ₈	(822.3)	2700		FSP3210WKF	2.2	(1.0)
	35 ⁵ / ₈	(904.9)	31 ⁷ / ₈	(809.6)	34 ⁷ / ₈	(885.8)	3000		FSP3410WKF	2.3	(1.1)
	38 ³ / ₈	(974.7)	34 ⁵ / ₈	(879.4)	37 ⁵ / ₈	(955.7)	3200		FSP3710WKF	2.4	(1.1)
42 ¹ / ₈	(1070.0)	38 ³ / ₈	(974.7)	41 ³ / ₈	(1050.9)	3600		FSP4110WKF	2.5	(1.2)	
47 ³ / ₄	(1213.0)	44	(1117.0)	47	(1193.0)	4000		FSP4610WKF	2.7	(1.3)	

• M - Manufacturing lead times