

STEEL MILLS

NONCONTACT TEMPERATURE MEASUREMENT

Coke Ovens

Blast Furnace

Steel Making

Continuous Caster

Hot Rolling

Annealing Line

Cold Mill

Coating Line

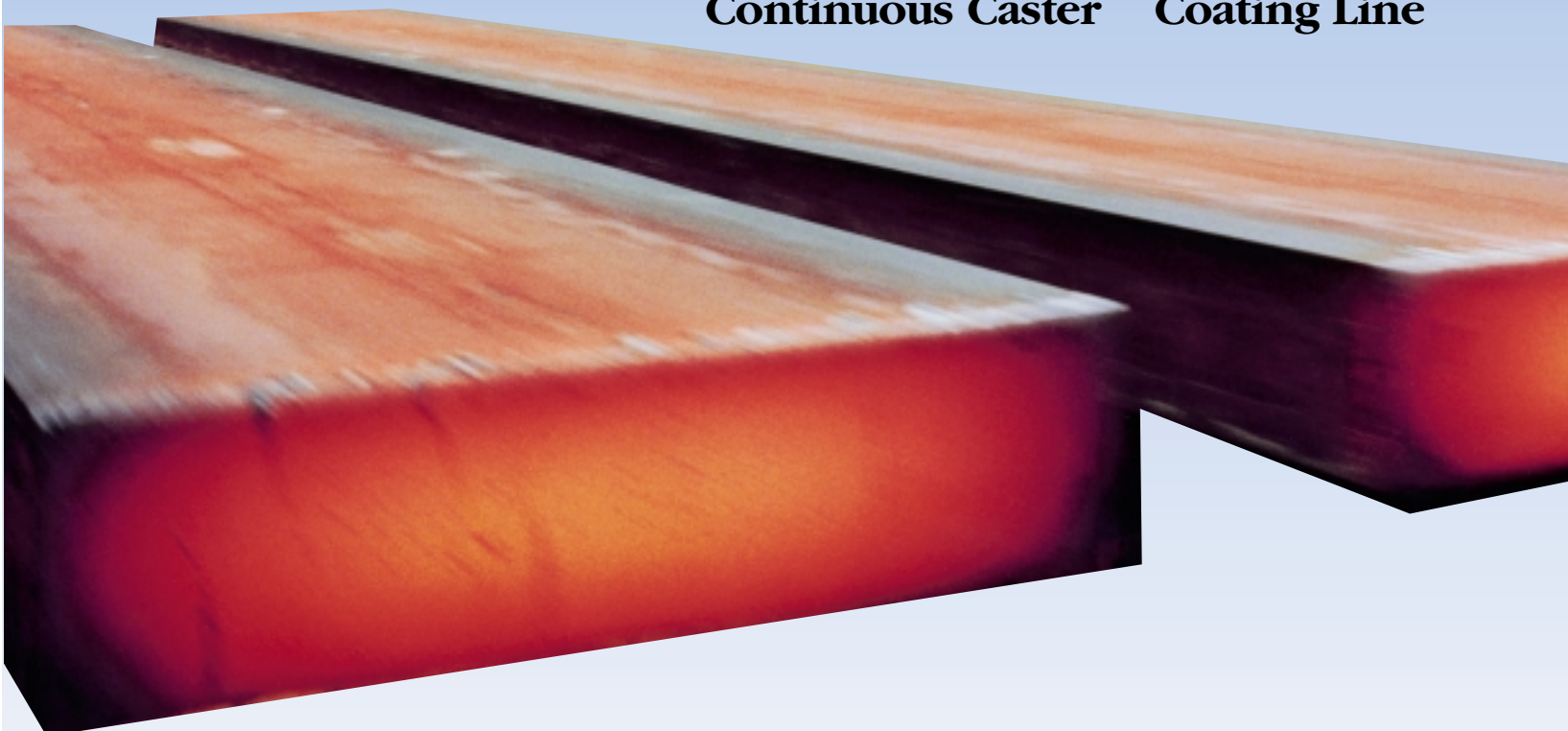

Williamson

Innovators in Noncontact Temperature Measurement

INNOVATORS IN NONCONTACT TEMPERATURE

Innovative Solutions for Traditional and New Steel Mill Applications

Williamson is dedicated to providing unique and creative solutions for steel mill applications. We offer a comprehensive line of industrial temperature sensors, as well as several innovative technologies for applications considered difficult to measure. Some significant sensor features include a patented single-wavelength **Auto Null Design**, a high-performance **Dual-Wavelength Design**, a patented **Multi-Wavelength Design**,

and a variety of flexible **Fiber Optic Systems**. Combining these unique capabilities with our extensive steel mill application experience, Williamson can provide superior performance for both traditional and difficult to measure applications. For greater details about our capabilities, call us today to discuss your application and to receive a free copy of our comprehensive, eighty-six page guide to steel mill temperature applications.

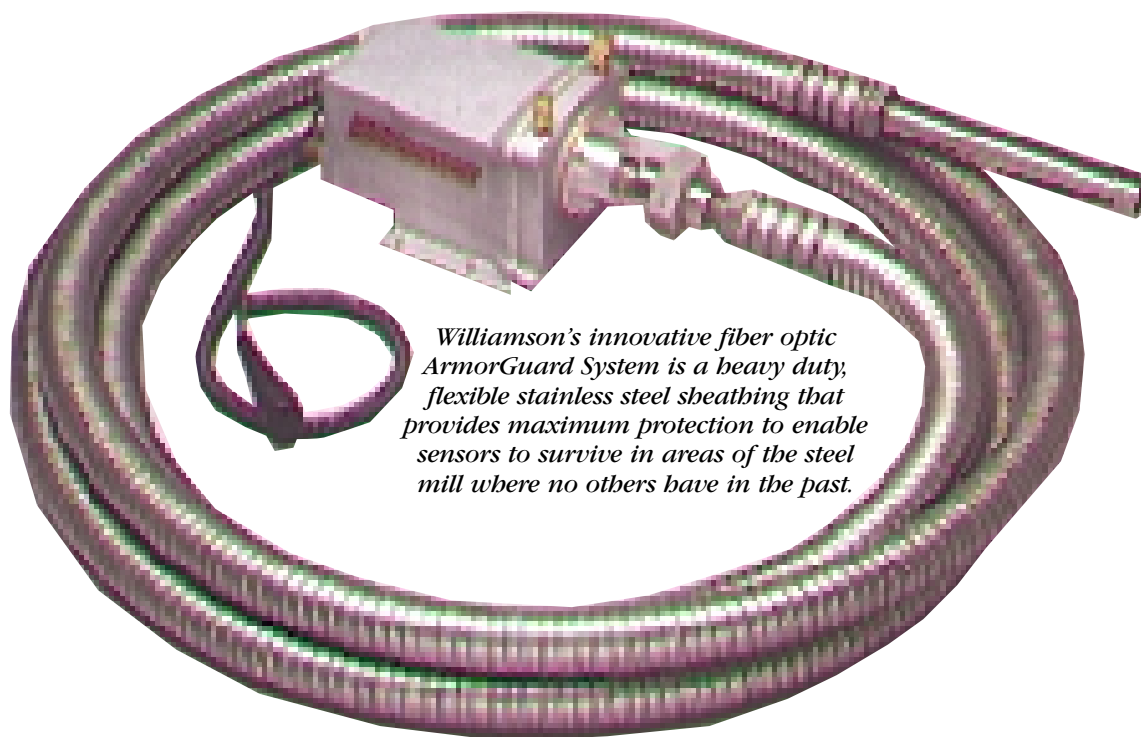









Williamson's innovative fiber optic ArmorGuard System is a heavy duty, flexible stainless steel sheathing that provides maximum protection to enable sensors to survive in areas of the steel mill where no others have in the past.

Greater Accuracy, Repeatability, and Reliability for Temperature Measurement and Control

With a complete selection of single-, dual-, and multi-wavelength sensors, Williamson can provide the system that best meets the required level of accuracy, repeatability, and reliability for each application. The table below highlights Williamson's unique

capabilities to effectively compensate for emissivity and to outperform all others, particularly when measuring ferrous and nonferrous metals.

Temperature Application	Recommended Sensor Design & Models	Unique Capability
Most Ferrous Metal Applications Which Exhibit Greybody Conditions	Below 500°F (250°C)  Single Wavelength  TempMatic 4200 Series  FiberView 5200 Series	These sensors provide greater accuracy and repeatability for low emissivity applications at temperatures as low as 125°F (50°C). With infrared filtering in the 2 micron range, errors due to changes in emissivity are minimized or eliminated. While the Patented Auto Null Design eliminates noise and calibration drift often associated with this type of sensor.
	Above 300°F (150°C)  Dual Wavelength  TempMatic 8000 Series  FiberView 9000 Series	These High-Performance Dual-Wavelength Sensors provide greater accuracy and repeatability on metal applications with emissivity variance and temperatures over 300°F (150°C). With an exceptionally high signal dilution factor, these sensors outperform all other ratio sensors.
Most Nonferrous Metal Applications Which Exhibit Non-Greybody Conditions	Above 400°F (200°C)  Multi Wavelength  TempMatic 12200 Series  FiberView 12200 Series	With a Patented Multi-Wavelength Design , these sensors provide accurate and repeatable measurements of nonferrous metals such as aluminum, copper, brass, and zinc. This capability is a Williamson exclusive that combines multi-wavelength hardware with a blending algorithm specifically developed for these difficult materials.

MEASUREMENT FOR THE STEEL INDUSTRY

Unequaled Performance For Difficult Applications

Williamson's 8000 and 9000 Series dual-wavelength sensors offer unique capabilities to meet the challenges of demanding steel mill applications. With the unique single detector design, these sensors offer a higher signal dilution factor that enables them to outperform all other ratio sensors. Specifically, this feature enables the Williamson sensors to operate properly when the target energy signal is diluted over 99%. Some typical steel temperature application issues that dilute a target energy signal are a low surface emissivity, dirty optics, scale, water spray, small targets or any combination of these conditions.

MAXIMUM SIGNAL DILUTION FACTOR VALUES

	Ratio Sensor	Typical Ratio
Williamson Sensors	8100/9100	1500:1
	8200/9200	500:1
	8300	100:1
Competitive Sensors	Two Color Design	25:1

Dual-Wavelength Features

- Automatic Emissivity Compensation
- Views through Dust & Dirty Optics
- Views through Water Spray
- Compensates for Scale & Oxide Formation
- Measures the Hottest Temperature Viewed
- Long-Term Calibration Stability
- Highest Signal Dilution Factor Available

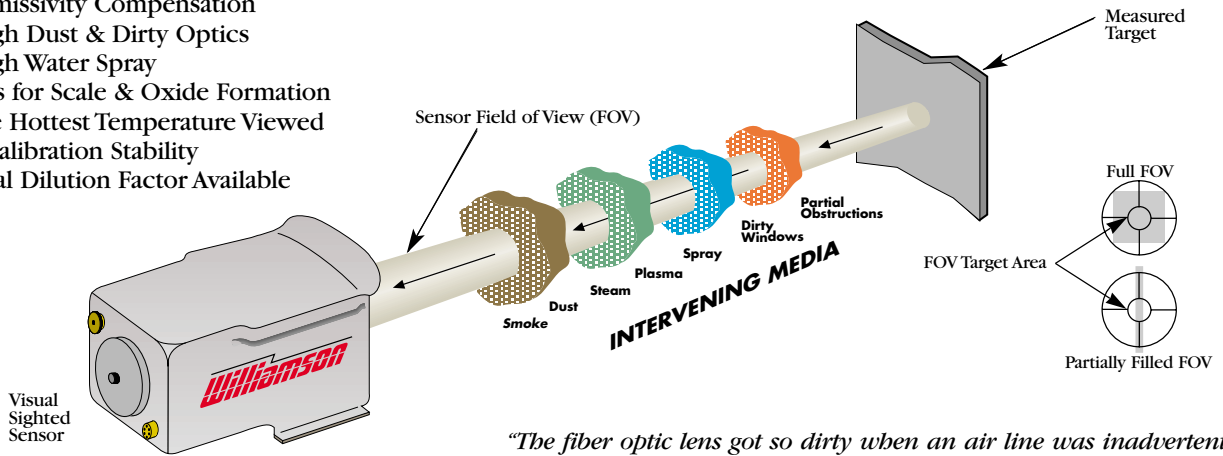

"The fiber optic lens got so dirty when an air line was inadvertently shut off that the aim light was undetectable. Upon checking the calibration with the dirty lens, I was amazed to find the reading still within 5 °F of the blackbody source." (John Olmsted—Stelco Steel)

More Durable Sensors, Easier Installation, and Less Maintenance

Through the use of innovative infrared technology, robust sensor design, and creative mounting and installation techniques, Williamson has made it simpler and easier to install and maintain its sensors. Each sensor is available in a system configuration with a remote display or as a stand alone sensor with a 4-20mA output. In addition, each sensor is available with either visual (SLR) sighting, laser aiming, or fiber optic alignment. Of particular

interest, the fiber optic design of the FiberView Series provides greater durability and flexibility for sensor installations. These fiber optic sensors are used for measurements within confined spaces or severe environments, and they include a wide selection of fiber optic accessories to customize each system.

Fiber Optic Features

- Views difficult to reach targets
- Measures targets in hostile environments
- More flexible for installation and alignment

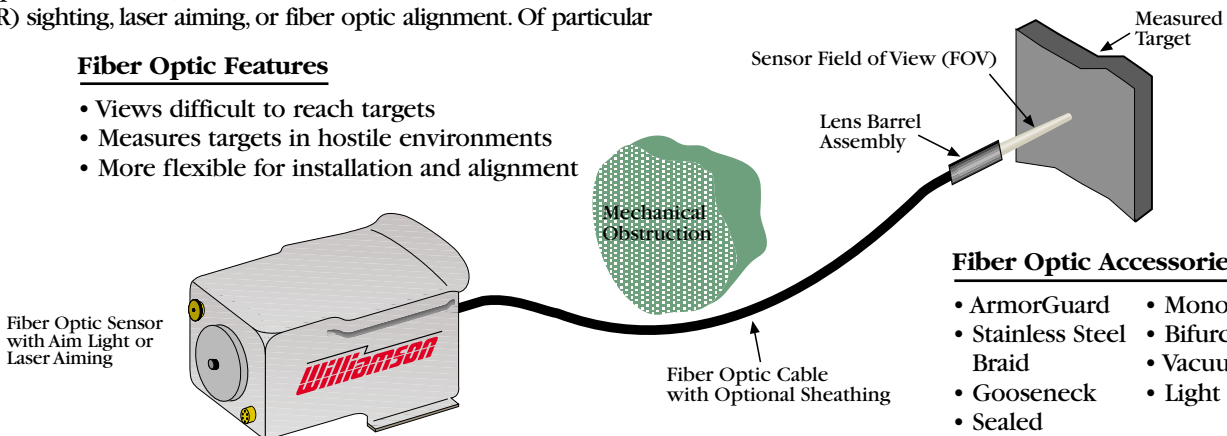

Fiber Optic Accessories

- ArmorGuard
- Stainless Steel Braid
- Gooseneck
- Sealed
- Monofilament
- Bifurcated Cables
- Vacuum Bushings
- Light Pipes

IMPROVING QUALITY AND PRODUCTIVITY THROUGH

ENGINEERED SOLUTIONS FOR THE ENTIRE STEEL MILL

The knowledge and use of noncontact temperature measurement throughout the steel making process is essential for the efficient production of quality steel. Some common benefits of real time temperature measurement and control in the steel making process include:

- Improved metallurgic properties and dimensional tolerances with instantaneous feedback of operating parameters
- Increased productivity through optimal process monitoring and control
- Cost savings through reduced scrap and improved energy and operating efficiency
- Minimized downtime through increased equipment life
- Increased personnel safety with better process monitoring and control in hazardous areas

COKE OVENS

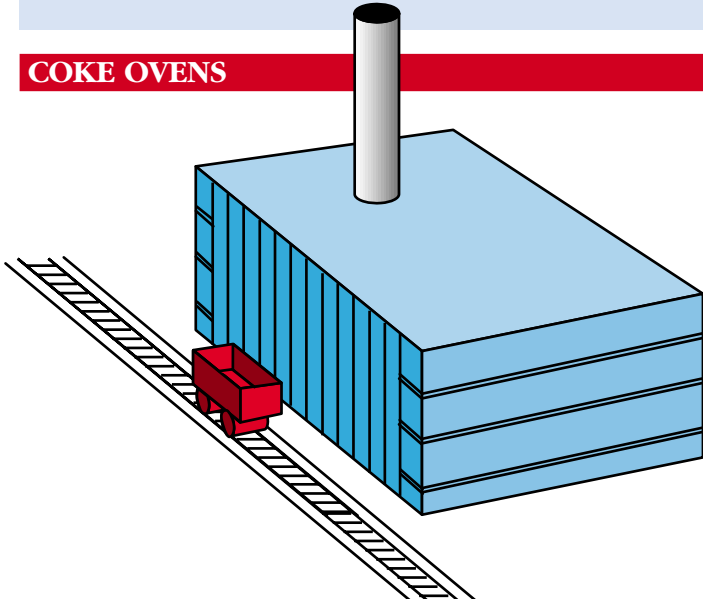

BLAST FURNACE

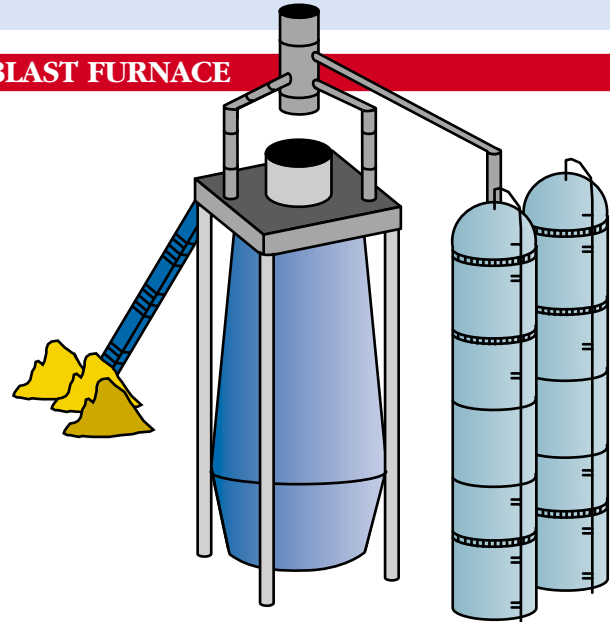

“The dual-wavelength system provides greater confidence in the measurement and more consistent heat delivery to the battery.”
(Ron Burnett—National Steel)

“The performance of the dual-wavelength sensor allowed us to get continuous tap temperature measurement for the first time.”
(Noel Clark—Lake Erie Steel Co.)

Temperature Applications

- Battery Profile  
- Coke Conveyor  
- Flare Monitor  

Application Highlights

In the coke ovens, fiber optic sensors are mounted on the door machine to monitor the coke temperature at varying levels during discharge. By monitoring these temperatures during a push, a complete temperature profile of the coke battery is obtained to ensure a complete and thorough cooking of the coke. Proper temperature control also ensures that the conversion process is complete and that the impurities are incinerated without the use of excessive energy. Cold and hot spots are the result of unbalanced gas distribution or clogged nozzles, and on-line temperature measurements help target prompt and cost effective maintenance.

The FiberView 9100 Series sensors have been designed to minimize maintenance requirements in this hot, dusty, and difficult-to-access area of the mill. With the rugged sensor design and the ability to view through dirty optics, Williamson’s unique dual-wavelength sensors virtually eliminate maintenance requirements.

Temperature Applications

- Stove Temperature  
- Blast Air  
- Tuyere  
- Iron Stream  
- Slag Conveyor  
- Torpedo Car  
- Flare Stack Monitor  

Application Highlights

In the blast furnace, sensors are mounted at the stove dome and along the side of the stove to verify the proper refractory temperatures and to eliminate overheating that can lead to excessive fuel costs and refractory wear. With a direct refractory temperature measurement, Williamson sensors provide more accurate measurements and require less maintenance than thermocouples. The dual-wavelength sensors are recommended when viewing through dirty windows.

For accurate and continuous iron stream temperature measurements the TempMatic 8100 is used. This information yields more consistent metal chemistry and provides precise tap times that aid in the calculation of process efficiency and iron levels. The sensor is aligned at the stream just after the skimmer block, and with the unique Williamson dual-wavelength design, the sensor effectively compensates for changing emissivity while viewing through the smoke and dirty optics that are common in the blast furnace area.

NONCONTACT TEMPERATURE MEASUREMENT

STEEL MAKING

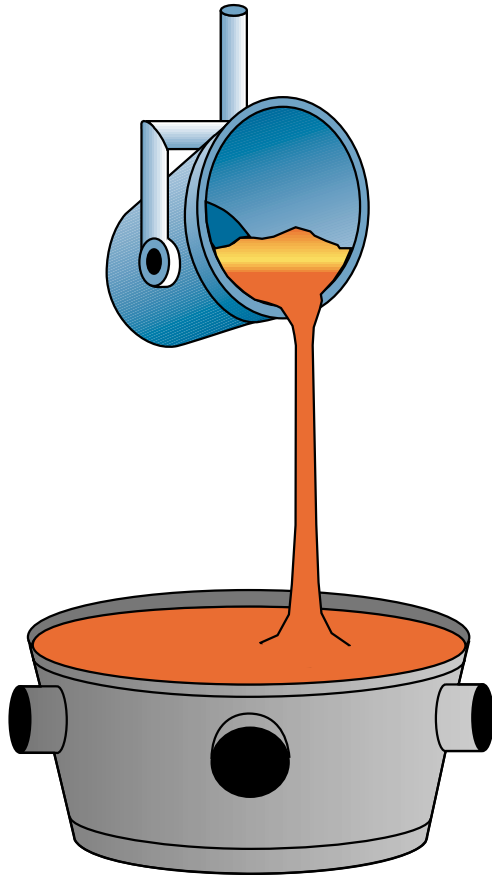

“The Williamson sensors have provided continuous, accurate, reliable service under extreme conditions. These sensors helped us to reduce our warm-up time from 3 hours to 35 minutes and to reduce fuel consumption by over 50%.”

(Larry Haniford—US Steel)

Temperature Applications

- Refractory Soak Control 
- Shroud Detector 
- Pouring Stations 
- Flare Monitor 

Application Highlights

In the steel making process, refractory-lined vessels are preheated to reduce thermal shock and to prevent excessive cooling of the metal during processing. Traditionally, thermocouples have been used to monitor preheat temperatures by measuring the gas temperature in the vessel. This indirect measurement technique results in varying degrees of accuracy and repeatability that are dependent upon the conduction and thermal intimacy of the thermocouples.

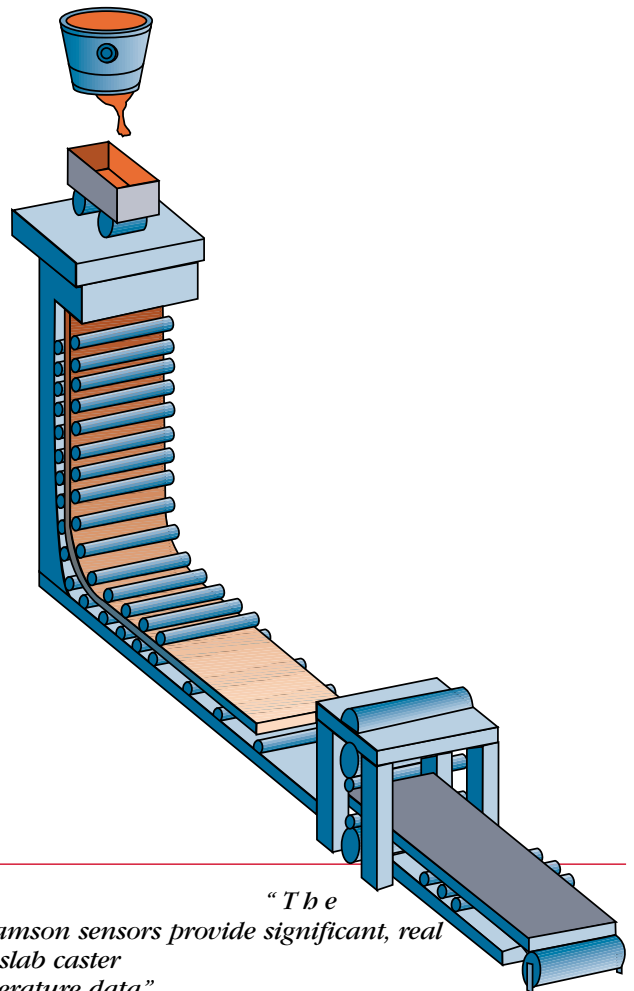

Williamson sensors replace thermocouples on ladles, tundish boxes, vacuum degas vessels, BOF vessels, shrouds, and iron transfer cars. With a direct refractory surface temperature measurement, Williamson sensors provide more accurate measurements to ensure that the proper setpoint temperature is achieved. This results in dramatic reductions in heating time and fuel consumption. The reduced heating time also extends refractory life for additional long-term cost benefits. Fiber optic sensors are recommended for most hot refractory wall measurements, while the ArmorGuard System is commonly used when direct flame impingement is anticipated.

CONTINUOUS CASTER



“The Williamson sensors provide significant, real time slab caster temperature data.”

Temperature Applications

- Slab/Strand—at Mold Exit 
- Slab/Strand—in Spray Chamber 
- Slab/Strand—on Run out Table 

Application Highlights

In the caster, product quality and throughput have a significant effect upon plant productivity and profitability. With real time temperature measurement in the containment section of the caster, process parameters can be verified and adjusted to optimize the process. With better control of the nozzle spray patterns and flow rates, temperature gradients that can result in cracking, loss of material properties, and additional wear on equipment may be eliminated. The overall result is a more efficient process yielding better quality steel and greater equipment life.

The FiberView 9100 ArmorGuard System is used to provide continuous slab temperature measurements within the containment zones of the caster. The unique dual-wavelength design provides accurate and reliable measurements as it views through water spray and dirty optics while automatically compensating for changes in emissivity, surface scale, oxides, and lubricant contaminants. This system has a proven record of virtually maintenance-free operation in this hostile environment where no others have survived in the past.

SOLVING PROBLEMS WITH INNOVATIVE TECHNOLOGY

HOT ROLLING MILL (SLAB OR BAR)

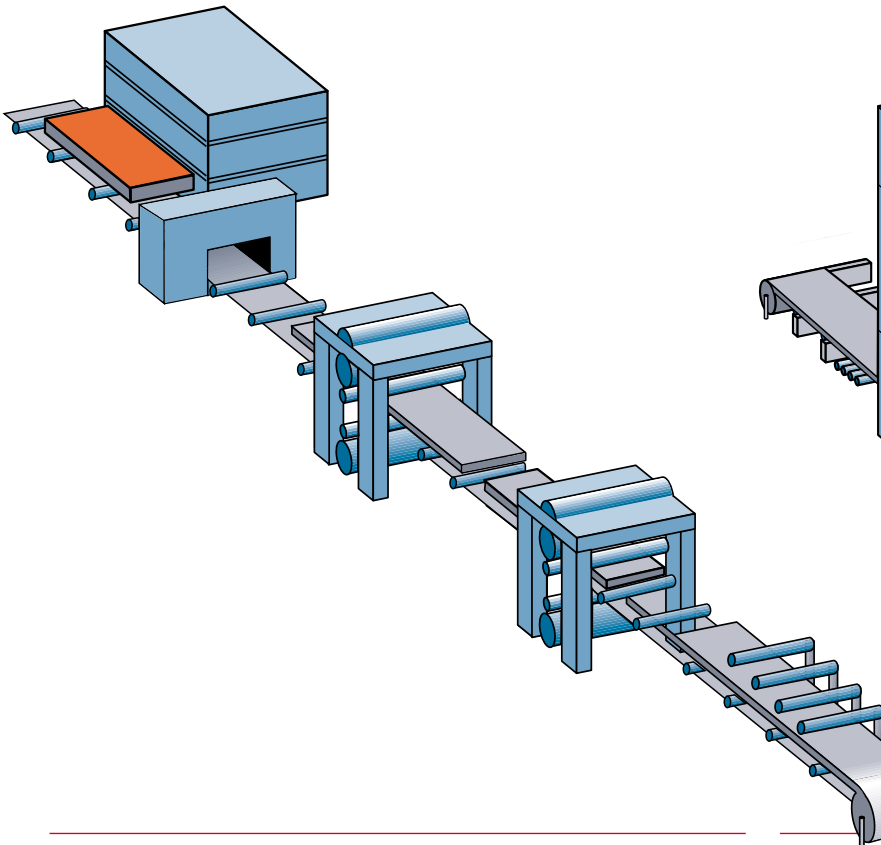

ANNEALING LINE

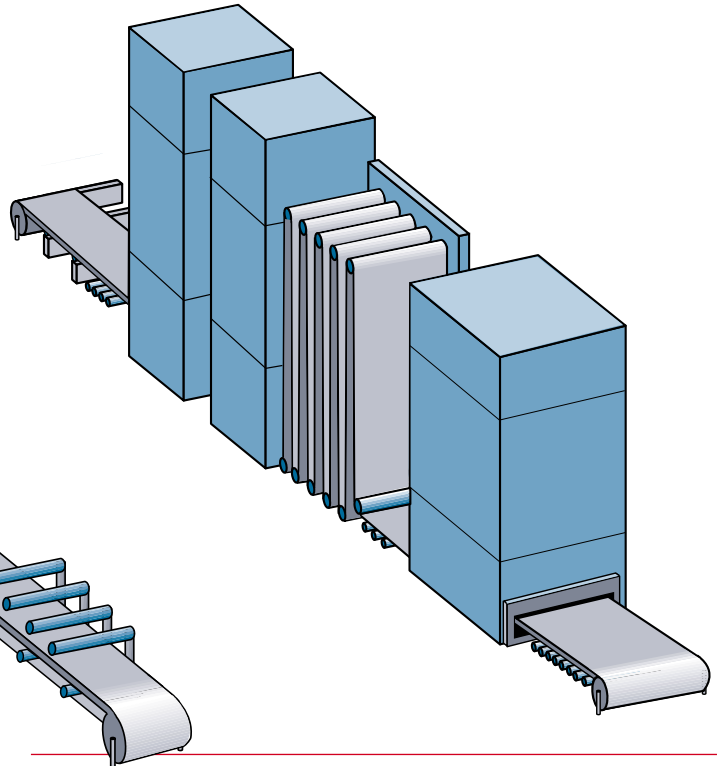

“Over the years, the TempMatic 8000 sensors have provided accurate and stable measurements as well as survived the mill environment. Our maintenance people think they are great!”
(Larry Tapani—Oregon Steel)

“These systems are so reliable, we don’t even need a spare.”
(Ralph Whitfield—Gulf States Steel)

Temperature Applications



- Reheat Furnace 
- Furnace Door Detector 
- Roller Temperature 
- Slab/Strip— Top & Bottom 
- Coiling Station 

Application Highlights

In the hot mill area, dual-wavelength sensors are used to measure slab, plate, bar, rod, wire, and strip temperatures where temperature uniformity is critical for the proper formation of steel (this includes the quenching and coiling station). During the rolling process, hotter areas tend to deform more than cooler areas, so temperature uniformity affects shape and mechanical properties. Top and bottom temperature control can also eliminate waves and cobbles in the rolled product.

Side-to-side and bulk strip temperatures are measured using the TempMatic 8000 Series, while the FiberView 9100 ArmorGuard System is used for underside measurements. With the high-performance dual-wavelength design, these sensors automatically compensate for dirty optics, water spray, and changes in strip emissivity. These capabilities eliminate the need to frequently clean sensor optics, and in the case of rod stock, they can effectively view a partially filled field of view.

Temperature Applications

- Welder 
- Strip in the Heating Zones 
- Strip in the Soaking/Cooling Zones 

Application Highlights

In the annealing process, a controlled time-temperature relationship is important to obtain the desired mechanical properties. Elevated temperatures relax internal stresses and establish the proper strip hardness. Temperature variations can result in unacceptable mechanical properties, while side-to-side or top-to-bottom temperature gradients cause product inconsistencies. Non uniform strip temperatures also adversely impact quality requirements downstream.

A variety of sensors are used for temperature control in the heating, soaking, and cooling zones. In the heating zones, creative sensor installation techniques can eliminate common sensor interferences due to reflections from hot furnace walls and radiant tube heaters as well as changes in strip emissivity. Wherever possible, the dual-wavelength sensors are recommended in order to provide the most effective compensation for uncertainty in strip emissivity. For quality control of the welded seam, the FiberView 9100 sensors are recommended for temperature monitoring and alarm.

THROUGHOUT THE STEEL MAKING PROCESS

COLD MILL

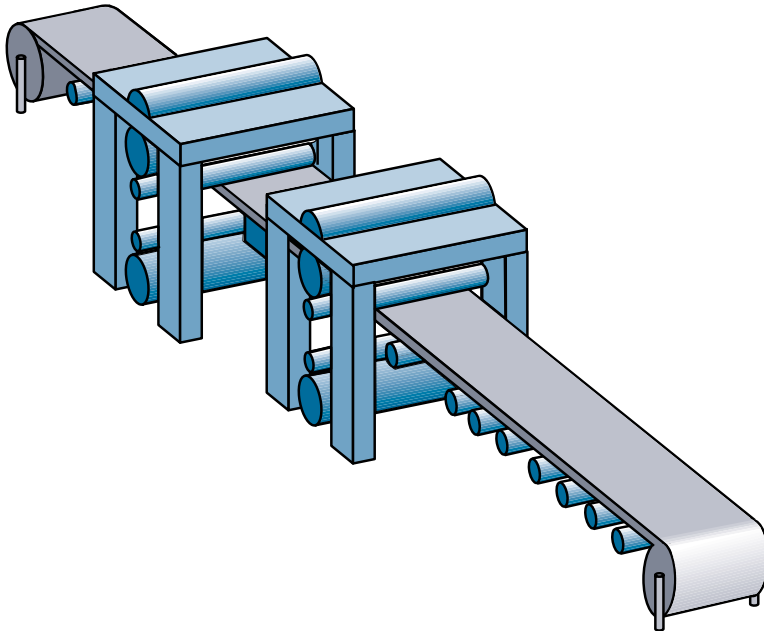

"In my experience, the Auto Null sensors are more accurate and reliable for low temperature measurements than anything else we have tried—and we've tried just about everything."

(Peter Ross—Ross Production Systems)

Temperature Applications

- Welder 
- Strip 

Application Highlights

For cold rolling in both tandem and reversing mills, temperature control is important to obtain the desired mechanical properties and surface finish of the steel strip. Strip temperatures are measured using the TempMatic 4200 or the FiberView 5200 Series sensors. These innovative sensors utilize a patented Auto Null technology that is designed to provide accurate temperature measurement for this low temperature, low emissivity application.

With infrared filtering at 2 microns, the 4200 and 5200 sensors minimize emissivity errors for accurate temperature measurement of cold rolled steel strip. These single-wavelength sensors measure as low as 125 °F (50 °C), and with their patented Auto Null design eliminate sensor noise and calibration drift. In addition, the fiber optic 5200 is a popular selection because it enables installation in a shadowed location near the roller. For quality control of the welded seam, the FiberView 9100 sensors are recommended for temperature monitoring and alarm.



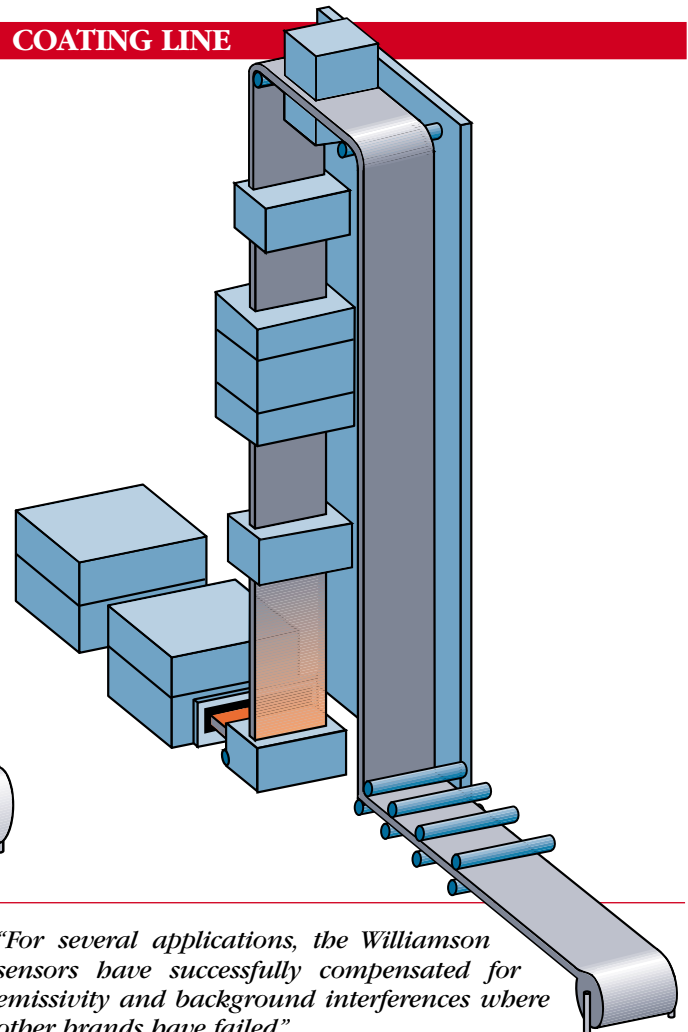

COATING LINE



"For several applications, the Williamson sensors have successfully compensated for emissivity and background interferences where other brands have failed."

(Jack Stewart—Thermation, Inc.)

Temperature Applications

- Uncoated Strip below 400 °F (200 °C) 
- Uncoated Strip above 400 °F (200 °C) 
- Coated Strip below 400 °F (200 °C) 
- Coated Strip above 400 °F (200 °C)
Al, Cu, Zn Coatings 
Pb, Sn(tin) Coatings 

Application Highlights

In the coating process, temperature control is required to ensure proper coating adhesion, surface finish, and mechanical properties. With Williamson's broad product capabilities, it is possible to select sensors that minimize emissivity sensitivity for accurate product temperature control of coated stock.

The single-wavelength 4200 and 5200 Auto Null sensors are used for low temperature strip and organic coating applications, while the dual-wavelength 8000 and 9000 Series sensors are used for applications above 400 °F (200 °C). Of particular significance, the multi-wavelength 12200 series sensors are used for nonferrous aluminum, copper, or zinc coating applications. This ability to provide accurate and repeatable measurements of nonferrous surfaces is an exclusive capability from Williamson. The patented 12200 design combines multi-wavelength hardware with a blending algorithm that was specifically developed for nonferrous materials.

SENSORS DESIGNED FOR STEEL MILL APPLICATIONS

Commitment to Innovative Technology, Application Expertise and Quality Service

For over 50 years, Williamson has been in the business of improving process control and product quality through non-contact temperature measurement. Through a worldwide distribution network, we offer a comprehensive line of industrial temperature sensors as well as several innovative technologies for applications considered difficult to measure. With extensive application experience focusing on solving customer problems, we are committed to providing quality service and support that is essential for building long-term customer partnerships.

This commitment includes:

- listening and working with our customers to provide the best possible solution for each application
- developing customized solutions for unique requirements
- providing knowledgeable and timely support before, during and after each sale.





Please contact us for more information about our products and unique capabilities. We would be pleased to provide the requested information and to discuss your specific application.

WILLIAMSON SENSOR SELECTOR GUIDE

Single Wavelength



MODELS:

-  *TransTemp 1000 Series*
-  *FiberView 1100 Series*
-  *TempMatic 4000 Series*
-  *FiberView 5000 Series*

TEMPERATURE LIMITS:

- 50 - 4500 °F
- 45 - 2500 °C

Designed for use in many general purpose applications where surface emissivity is reasonably constant, Williamson's single-wavelength sensors offer broad temperature and infrared spectral response selections and a variety of optical options. Low temperature fiber optic sensors, small spot optics, and distant optics with visual or laser aiming are available to meet specific application requirements. The short wavelength 4200 and 5200 Series with the Auto Null Technology are excellent for low temperature, low emissivity applications. The Transtemp 1000 and FiberView 1100 Series also offer single-wavelength capabilities in a convenient and cost-effective two-wire transmitter configuration.

Dual Wavelength



MODELS:

-  *TempMatic 8000 Series*
-  *FiberView 9000 Series*

TEMPERATURE LIMITS:



- 300 - 4400 °F
- 150 - 2425 °C

These dual-wavelength sensors are designed for difficult to measure materials and hostile operating environments where single-wavelength sensors have limited effectiveness. Dual-wavelength sensors provide automatic compensation for low and varying emissivity of greybody surfaces as well as for interference from smoke, steam, heavy scale, dirty windows, water spray, or dust. These sensors also measure the hottest temperature in the Field of View and are effective for stream, flame, and wire measurements. The unique, single detector design offers an exceptionally high signal dilution factor and drift-free calibration stability for maximum performance with demanding applications.

Multi Wavelength



MODELS:

-  *TempMatic 12200 Series*
-  *FiberView 12200 Series*

TEMPERATURE LIMITS:

- 400 - 2000 °F
- 200 - 1100 °C

This patented, multi-wavelength sensor is designed specifically for measuring difficult surfaces like aluminum, copper, brass, and zinc, as well as galvanized steel. The sensor uses multi-wavelength hardware and a unique blending algorithm that was developed based on the non-greybody surface characteristics of these materials. This innovative technology provides non-contact temperature measurement and control accuracy never before achieved with applications involving these non-ferrous metal materials.

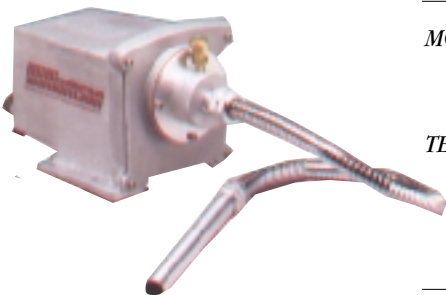
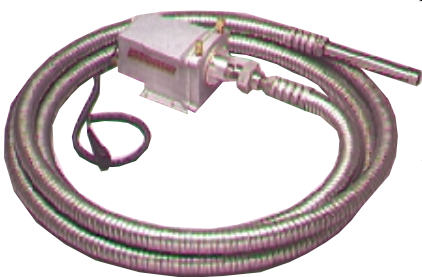

2 Year Warranty
on All Sensors



WILLIAMSON CORPORATION
70 Domino Drive, Concord, Massachusetts 01742
TEL: (978) 369-9607 • FAX: (978) 369-5485 • (800) 300-8367 (USA)

Williamson
Innovators in Noncontact Temperature Measurement