

Addendum to:  
**QPAC** Style E SCR  
 Power Controller

# User's Manual

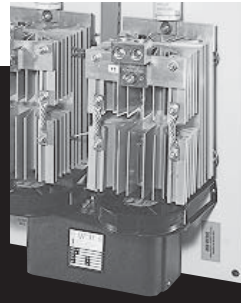

**WARNING:**  
 Style E heatsinks are electrically HOT.  
**CAUTION:** Mount the QPAC vertically (height dimension vertical) for proper cooling. Failure to do so could result in power control malfunction.

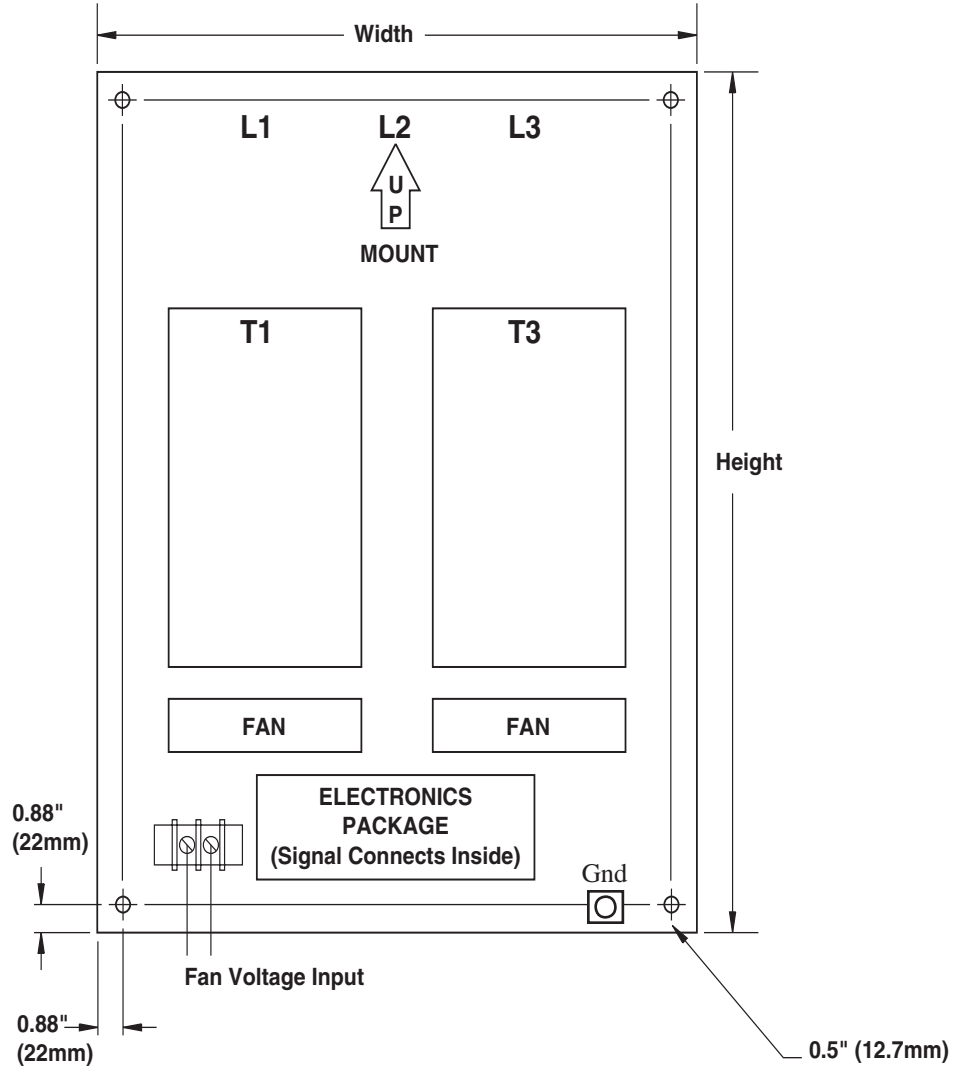

Overall Panel Dimensions

Model	Amps	Height in (mm)	Width in (mm)	Depth in (mm)	Weight lbs (kg)
Q01(1 fan, 1 fuse on board)	400-600	27 (685)	17 (430)	11.7 (300)	44 (19.9)
	800-1000	27 (685)	17 (430)	13.3 (340)	49 (22.2)
Q32 (2 fans, 2 fuses on board)	400-600	27 (685)	21 (535)	11.7 (300)	85 (38.5)
	800-1000	33 (840)	21 (535)	13.3 (340)	120 (54.4)
Q33 (3 fans, 3 fuses on board)	400-600	33 (840)	27 (685)	11.7 (300)	100 (45.4)
	800-1000	33 (840)	27 (685)	13.3 (340)	135 (61.2)

Watlow Controls  
 1241 Bundy Blvd.  
 P.O. Box 5580  
 Winona, MN 55987-5580  
 Phone: 507-454-5300  
 Fax: 507-452-4507



**WARNING:**  
Style E heatsinks are electrically HOT.

**CAUTION:** Check terminals for tightness before applying power and then recheck terminals after one day of operation. Loose connections can damage the SCR.

**1 NOTE:** On 120VAC or 277VAC, L2 is neutral and cannot be broken.

**2 NOTE:** A contactor is required if a high limit control is used.

**3 NOTE:** A separate disconnect is required for the fan(s).

**4 NOTE:** Use 14 - 16 gauge wire for control power only.

**NOTE:** A circuit breaker is required in addition to the semiconductor fuses. All semiconductor fuses are mounted onboard the QPAC models 400-1000. Where third leg fusing is selected, additional space is required.

**NOTE:** QPAC models Q01, Q32 400 to 1000 Amps up to 480VAC are agency approved. Q33 400 to 1000 Amps are not agency listed.



**WARNING:**  
To avoid damage to property and equipment, and/or injury or loss of life, use National Electric Code (NEC) standard wiring practices to install and operate the QPAC. Failure to do so could result in damage, and/or injury or death.

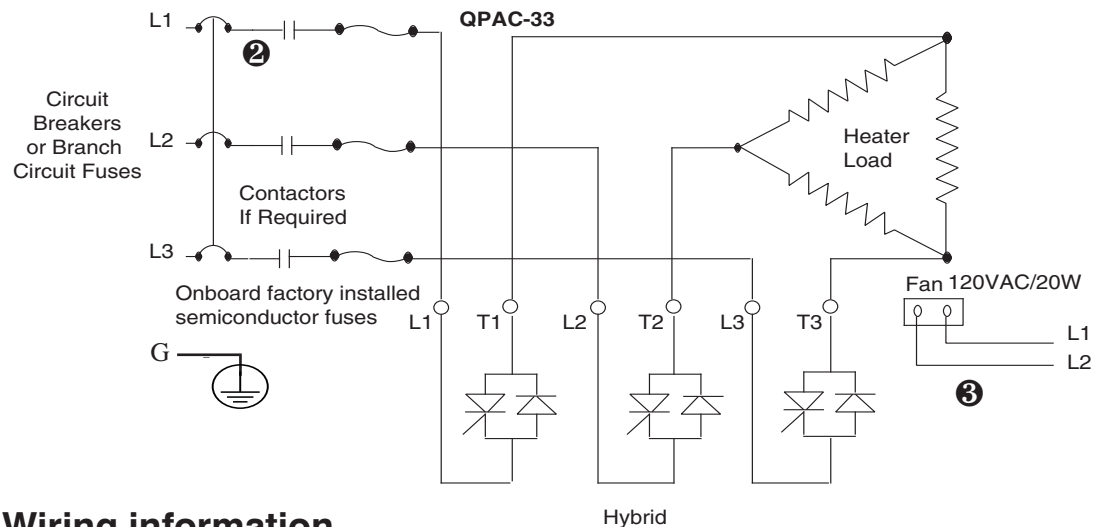
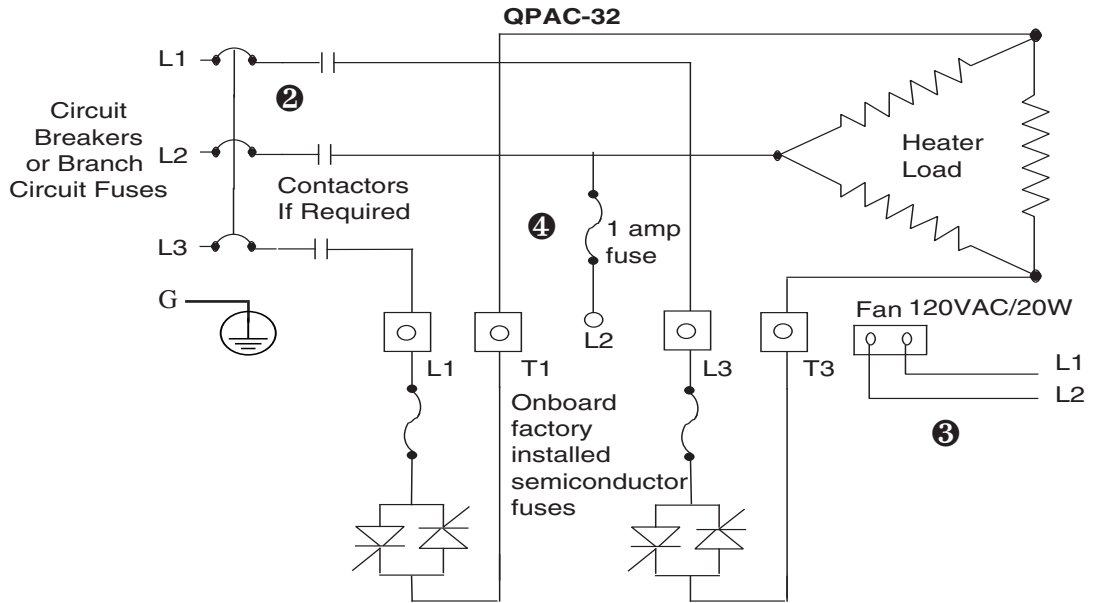
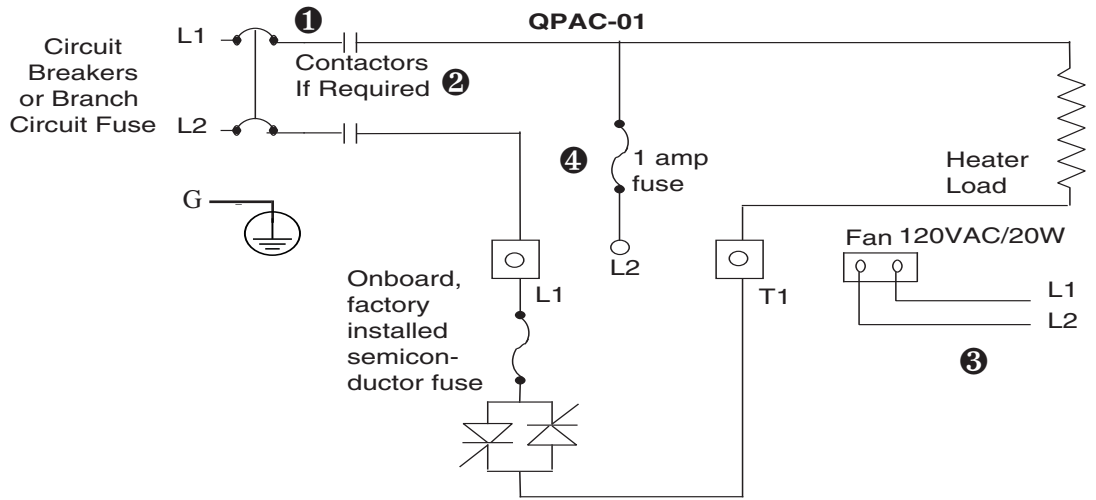

## Wiring information

Load Current in Amperes	Semiconductor Fuse Rating	Minimum Recommended Wire Size	Wire Bending Radius in (mm)	Lugs will Accept Wire No.	Lug Torque	Internal Allen Head Lug
400	500	Dual 350 MCM	15 (380)	2 to 600 MCM	500 in/lb.	1/2"
500	600	Dual 350 MCM	15 (380)	2 to 600 MCM	500 in/lb.	1/2"
600	800	Dual 500 MCM	15 (380)	2 to 600 MCM	500 in/lb.	1/2"
800	1000	Quad 250 MCM	15 (380)	2 to 600 MCM	375 in/lb.	3/8"
1000	1250	Quad 350 MCM	15 (380)	2 to 600 MCM	375 in/lb.	3/8"